



Agilent Technologies L4490A/L4491A RF Switch Platform



User's Guide

Errata

Agilent References in this manual

NOTICE: This document contains references to Agilent Technologies. Agilent's former Test and Measurement business has become Keysight Technologies. For more information, go to:

www.keysight.com

About this manual

We've added this manual to the Keysight website in an effort to help you support your product. This manual provides the best information we could find. It may be incomplete or contain dated information.

Support for your product

You can find information about technical and professional services, product support, and equipment repair and service on the web:

www.keysight.com

Select your country from the drop-down menu at the top. Under *Electronic Test and Measurement*, click on *Services*. The web page that appears next has contact information specific to your country.

For more detailed product information, go to: www.keysight.com/find/ *<product model>*
i.e., for the M9514A, use: www.keysight.com/find/M9514A

Hypertext links to documents on agilent.com are no longer active. Use this substitution to access PDF files:

Broken links have the form: <http://cp.literature.agilent.com/litweb/pdf/> *< literature_part_number >*

Substitute links with this form: <http://literature.cdn.keysight.com/litweb/pdf/> *< literature_part_number >*

Where *< literature_part_number >* has the form: M9300-90001.pdf

For service notes, use: www.keysight.com/find/servicenotes

Notices

© Agilent Technologies, Inc. 2011, 2012

No part of this manual may be reproduced in any form or by any means (including electronic storage and retrieval or translation into a foreign language) without prior agreement and written consent from Agic. as governed by United States and international copyright laws.

Manual Part Number

L4490-90001

Edition

Fifth Edition. September 2012

Printed in Malaysia

Agilent Technologies, Inc.
3501 Stevens Creek Blvd.
Santa Clara, CA 95052 USA

Microsoft® and Windows® are U.S. registered trademarks of Microsoft Corporation.

Software Revision

This guide is valid for the firmware that was installed in the instrument at the time of manufacture. However, upgrading the firmware may add or change product features. For the latest firmware and documentation, go to the product page at:

www.agilent.com/find/L449xA
www.agilent.com/find/L4490A
www.agilent.com/find/L4491A

Warranty

The material contained in this document is provided “as is,” and is subject to being changed, without notice, in future editions. Further, to the maximum extent permitted by applicable law, Agilent disclaims all warranties, either express or implied, with regard to this manual and any information contained herein, including but not limited to the implied warranties of merchantability and fitness for a particular purpose. Agilent shall not be liable for errors or for incidental or consequential damages in connection with the furnishing, use, or performance of this document or of any information contained herein. Should Agilent and the user have a separate written agreement with warranty terms covering the material in this document that conflict with these terms, the warranty terms in the separate agreement shall control.

Technology Licenses

The hardware and/or software described in this document are furnished under a license and may be used or copied only in accordance with the terms of such license.

Restricted Rights Legend

U.S. Government Restricted Rights. Software and technical data rights granted to the federal government include only those rights customarily provided to end user customers. Agilent provides this customary commercial license in Software and technical data pursuant to FAR 12.211 (Technical Data) and 12.212 (Computer Software) and, for the Department of Defense, DFARS 252.227-7015 (Technical Data - Commercial Items) and DFARS 227.7202-3 (Rights in Commercial Computer Software or Computer Software Documentation).

Safety Notices

CAUTION

A **CAUTION** notice denotes a hazard. It calls attention to an operating procedure, practice, or the like that, if not correctly performed or adhered to, could result in damage to the product or loss of important data. Do not proceed beyond a **CAUTION** notice until the indicated conditions are fully understood and met.

WARNING

A **WARNING** notice denotes a hazard. It calls attention to an operating procedure, practice, or the like that, if not correctly performed or adhered to, could result in personal injury or death. Do not proceed beyond a **WARNING** notice until the indicated conditions are fully understood and met.

Safety Notices

The following general safety precautions must be observed during all phases of operation of this instrument. Failure to comply with these precautions or with specific warnings or instructions elsewhere in this manual violates safety standards of design, manufacture, and intended use of the instrument. Agilent Technologies assumes no liability of the customer's failure to comply with the requirements.

General

Do not use this products in any manner not specified by the manufacturer. The protective features of this product may be impaired if it is used in a manner not specified in the operation instructions.

Before Applying Power

Verify that all safety precautions are taken. Make all connections to the unit before applying power.

Ground the Instrument

This product is provided with protective earth terminals. To minimize shock hazard, the instrument must be connected to the ac power mains through a grounded power cable, with the ground wire firmly connected to an electrical ground (safety ground) at the power outlet. Any interruption of the protective (grounding) conductor or disconnection of the protective earth terminal will cause a potential shock hazard that could result in personal injury.

Do Not Operate in an Explosive Atmosphere

Do not operate the instrument in the presence of flammable gases or fumes.

Removing the Instrument Cover

Only qualified, service-trained personal who are aware of the hazards involved should remove instrument covers. Always disconnect the power cable and any external circuits before removing the instrument cover.

In Case of Damage

Instruments that appear damaged or defective should be made inoperative and secured against unintended operation until they can be repaired by qualified service personnel.

Safety Symbols

 Alternating Current

 Direct Current

 Earth Ground

 Chassis Ground

 Standby Supply. Unit is not completely disconnected from AC Mains when switch is off

 Risk of electric shock

 REfer to manual for additional safety information

 Device or assembly is susceptible to damage from an ESD event

Waste Electrical and Electronic Equipment (WEEE) Directive 2002/96/EC

This product complies with the WEEE Directive (2002/96/EC) marking requirement. The affixed product label (see below) indicates that you must not discard this electrical/electronic product in domestic household waste.

Product Category: With reference to the equipment types in the WEEE directive Annex 1, this product is classified as a "Monitoring and Control instrumentation" product.

Do not dispose in domestic household waste.

To return unwanted products, contact your local Agilent office, or see www.agilent.com/environment/product for more information.



Declaration of Conformity

Declarations of Conformity for this product and for other Agilent products may be downloaded from the Internet. There are two methods to obtain the Declaration of Conformity:

- Go to <http://www.keysight.com/go/conformity>
. You can then search by product number to find the latest Declaration of Conformity.
- Alternately, you can go to the product web page (www.agilent.com/find/L4490A), click on the Document Library tab then scroll down until you find the Declaration of Conformity link.

Contents

1 About the Instrument

L4490A/L4491A Use Model	2
Equipment Inventory	3
Materials Included	3
Input Power and Operating Environment	3
Recommended Accessories	4
Installing Switches/Attenuators in the RF Switch Platform	6
Removing the RF Platform Covers	6
Bracket-Switch Assembly	7
L4490A/L4491A Switch Trays and Options	13
L4490A/L4491A Bracket Layout Guidelines	20

2 Hardware Configuration

Network Configuration	22
Selecting a LAN Network	22
Instrument Configuration	23
The 34945EXT Module	25
Channel Numbering	27
Internal/External Power Supply Considerations	28
Agilent Switch/Attenuator Configuration	31
Agilent N1810 / N1811 / N1812 Series Coaxial Switches	32
Agilent 87104/87106/87406 - L7104/L7106/L7204/L7206 Coaxial Switches	33
Agilent 87204 / 87206/ 87606 Series Coaxial Switches	34
Agilent 8767/8/9M Microwave Single-Pole Multi-Throw Switches	35
Agilent 84904/6/7 K/L and 84904/5/8M Programmable Step Attenuators	36
Agilent 8494/5/6/7 Programmable Step Attenuators	37
Agilent 849xG/H/K Programmable Step Attenuators Option 016	38
Agilent 87222 and L7222 Coaxial Switches	39
Agilent 8762 / 8763 / 8764 Series Coaxial Switches	40
Agilent 8765 Series Coaxial Switches	41
Agilent 8766/7/8/9K Microwave Single-Pole Multi-Throw Switches	42
Agilent U9397A / U9397C FET Solid State Switches	43

3 Software Installation and Configuration

Software Requirements	46
Installing the Agilent IO Libraries	47
Installing Instrument Drivers	48
Adding Instruments to the Interface	49
Configuring the LAN Interface	49
Configuring the GPIB Interface	53

Using Interactive IO	56
Applying Power	57
LAN Default Configuration	58
Firmware and Driver Updates	58
Downloading and Installing the Update Utility	58
Downloading the Firmware Update	59
Installing the Firmware Update	59
Updating the L4491A with Option 002	61
Downloading IVI-COM Driver and LabVIEW Driver Updates	63

4 Introduction to Programming

	66
Getting Started with the L4490A/L4491A Web-Enabled Interface	66
Connecting to the Instrument and Viewing its Home Page	67
An Overview of the 'Browser Web Control' Page	67
SCPI Command Interface	72
Logging SCPI Commands	73
System Verification	75
Switch and Attenuator Programming	80
Agilent N1810/N1811/N1812 Series Switches	80
Agilent 87104/87106/87406 - L7104/L7106/L7204/L7206 Switches	82
Agilent 87204 / 87206 Series and 87606 Switches	84
Agilent 8490x Series / 849x Series Attenuators and 876xM Series Switches	86
Agilent 87222 Series and L7222C Switches	88
Agilent 876x Series and U9397A/C Switches	90
Sequence Programming	92
Using L4490A/L4491A Digital IO and Relay Driver Option 004	93
Connector Pin Definitions	93
Configuring the Digital IO and Relay Drive Lines	96
Power-On, *RST, and SYSTem:CPON States	96
Restoring L4490A/L4491A Factory Settings	97

5 Additional Operating Information

L4490A/L4491A SCPI Command Summary	100
Y1150A - Y1155A Switch Control Tables	104
Y1150A Switch Control	104
Y1151A Switch Control	104
Y1152A Switch Control	105
Y1153A Switch Control	106
Y1154A Switch Control	106
Y1155A Switch Control	107
Drive Modes	109
Using Single-Coil Switches and Attenuators	110
Continuous Drive Mode	110

Single Coil with Separate Position Indicators Connection Diagram	111
Using Dual-Coil Switches and Attenuators	112
Pairing Channels	113
Paired Drive With Separate Position Indicators	113
Paired Drive With Combined Position Indicators	114
Pulsed Actuation Mode	115
Overcurrent Conditions	117
Overcurrent Conditions with External Supplies	118
Command Execution Times	118
Verifying Switch States	119
LED Drive Indicators	120
L4490A/L4491A Digital IO and Relay Driver Option 004	121
Digital I/O Functions	121

A Y1157A - Y1159A Cable Assembly Instructions

Y1157A Cable Kit Assembly	124
Y1158A Cable Kit Assembly	126
10-pin to 10-pin Cable	126
14-pin to 10-pin Cable	127
Y1159A Cable Kit Assembly	129



1 About the Instrument

L4490A/L4491A Use Model	2
Equipment Inventory	3
Materials Included	3
Input Power and Operating Environment	3
Recommended Accessories	4
Installing Switches/Attenuators in the RF Switch Platform	6
Removing the RF Platform Covers	6
Bracket-Switch Assembly	7
L4490A/L4491A Switch Trays and Options	13
L4490A/L4491A Bracket Layout Guidelines	20

Welcome. This manual contains component, configuration, and programming information for the Agilent L4490A/L4491A RF Switch Platform.

The L4490A and L4491A control and monitor RF/microwave switches and attenuators used in applications such as wireless communications, avionics, medical electronics, and in test and measurement systems. The L4490A and L4491A are optimized for use with the Agilent family of RF/microwave switches and attenuators.

The L4490A is a 2U, and the L4491A is a 4U LXI Class C instrument. LXI, an acronym for LAN eXtensions for Instrumentation is an instrumentation standard for devices that use the Ethernet (LAN) as their primary communication interface. The 2U and 4U references refer to the physical size of the L4490A and L4491A relative to standard EIA rack cabinet dimensions.

Refer to this chapter for specific information on:

- the use model for the L4490A/L4491A product and documentation
- materials (cables, hardware, software) supplied with the L4490A/L4491A
- input power and operating/storage specifications
- supported Agilent RF/microwave switches and attenuators
- distribution boards and brackets required for using the switches and attenuators in the RF switch platforms
- installing switches and attenuators in the platforms



L4490A/L4491A Use Model

The use model for the L4490A and L4491A RF switch platform and for this manual is:

- 1 Inventory and identification of standard L4490A/L4491A components and recommended switch/attenuator accessories (**Chapter 1**).
- 2 Connecting switches/attenuators to their brackets and installation of the switch/bracket assembly in the RF switch platform (**Chapter 1**).
- 3 Wiring the switches/attenuators to the distribution boards and installing the distribution boards in the RF switch platform (**Chapter 2**).
- 4 Configuring the system software in preparation of switch/attenuator configuration and control. Applying power to the switch platform (**Chapter 3**).
- 5 Programming (configuration and control) of the switches and attenuators (**Chapter 4**).

Reference information for selected topics in chapters 1-4 is located in **Chapter 5**. Detailed information on the L4490A/L4491A command set, as well as an on-line copy of this manual, instrument drivers, application notes, and computer-aided design (CAD) models for building RF cables are included on the **Product Reference CD ROM**.

When using this manual, note that chapters 1, 2, and 4 are organized by switch and attenuator model and the same sequence is found throughout the chapters.

Equipment Inventory

The first step prior to using the L4490A/L4491A for switch and attenuator control is to verify that all materials and accessories required for a given switch or attenuator model are available. This section lists the materials that ship standard with each L4490A/L4491A instrument.

Materials Included

The following materials are included with the L4490A and L4491A:

- 1 Power Cord
- 2 LAN cross-over cable
 - for a **direct** LAN connection between the L4490A/L4491A and the PC
- 3 Agilent L4490A/L4491A Product Reference CD-ROM (p/n L4490-13601)
 - manuals, instrument drivers, application notes, CAD models
- 4 Agilent E2094Q IO Libraries Media Suite
 - VISA/VISA-COM libraries, Agilent Connection Expert

Input Power and Operating Environment

The input power, operating environment, and storage environment specifications for the L4490A/L4491A are listed in Table 1-1. Refer to the instrument data sheet for a complete listing of specifications. The data sheets can be found on the Web at:

www.agilent.com/find/L449xA
www.agilent.com/find/L4490A
www.agilent.com/find/L4491A

Table 1-1. L4490A and L4491A Instrument Input Power Specifications.

Description	
Power Supply and Line Frequency:	100 - 240V \pm 10% 50/60 Hz
Power Consumption:	100 - 200 VA
Operating Environment:	Full accuracy for 0°C to 55°C Full accuracy to 80% R.H. at 40°C
Storage Environment:	-40°C to 70°C

The L4490A/L4491A should be operated in an indoor environment where temperature and humidity are controlled. Condensation can pose a potential shock hazard. Condensation can occur when the modules are moved from a cold to a warm environment, or if the temperature and/or humidity of the environment changes quickly.

Recommended Accessories

Switches and attenuators interface to the L4490A/L4491A through distribution boards. The Y1150A - Y1155A distribution boards are ordered separately based on the switches/attenuators used in your application. Similarly, recommended cables are included with the Y1170A-Y1175A series of mounting bracket kits, and are available individually in the Y1157A - Y1159A cable kits. Like the distribution boards, the bracket kits and cable kits are ordered separately.

Table 1-2 lists some of the common Agilent switches/attenuators and the distribution boards, bracket kits, and/or cable kits they require. **Review Table 1-2 carefully to ensure that you have the appropriate accessories for your switches and attenuators. This will save you time and frustration!**

Table 1-2. Recommended Accessories for Agilent Switches/Attenuators.

Switch Model	Reference Document Number ⁽¹⁾	Coil Voltage Option	Position Indicator Option	DC Connector Option	Distribution Board [number of switches per board]	Bracket Kit ⁽³⁾ [Cable Kit] ⁽³⁾
N1810UL N1810TL N1811TL N1812UL	5968-9653E	124	402/403 ⁽²⁾	201 (DB9F)	Y1150A [8] Y1152A [2] Y1154A [6]	Y1170A: L4491A Y1171A: L4490A [Y1157A]
87104A - C 87106A - C 87406B	5091-3366E 5965-7841E	024	standard	161 (16-pin DIP)	Y1151A [2]	Y1172A [Y1159A]
87204A - C 87206A - C 87606B	5965-3309E 5965-7842E	standard	standard	161 (16-pin DIP)	Y1152A [1]	Y1172A [Y1159A]
87222C - E	5968-2216E	standard	standard	161 (16-pin DIP)	Y1154A [2]	Y1173A [Y1158A]
L7104A - C L7106A - C L7204A - C L7206A - C	5989-6030EN	024	standard	161 (16-pin DIP)	Y1151A [2]	Y1172A [Y1159A]
L7222C	5989-6084EN	standard	standard	161 (16-pin DIP)	Y1154A [2]	Y1173A [Y1158A]
8762A - C 8763A - C 8764A - C 8762F	5952-1873E 5964-3704E	024	n/a	solder terminals (standard)	Y1155A [8]	Y1170A:L4491A Y1171A:L4490A
8765A - D 8765F	5952-2231E 5091-2679E	324	n/a	solder terminals (with 324)	Y1155A [8]	Y1170A:L4491A Y1171A:L4490A
8766K - 7K 8768K - 9K	5959-7831	024	n/a	060 (12-pin Viking)	Y1155A [2] Y1155A [1]	Y1175A
8767M - 9M	5988-2477EN	024	n/a	10-pin DIP	Y1153A [2]	Y1175A [Y1158A]
U9397A,C	5989-6088EN	standard	n/a	solder terminals	Y1155A [8]	Y1170A:L4491A Y1171A:L4490A

(1) For product and technical overviews, go to <http://www.agilent.com/find/accessories>, select 'RF & Microwave Test Accessories'. Additional information can also be found in the "RF and Microwave Test Accessories Catalog" accessible from this site.

(2) Starting in June 2010, the current interrupt function (formerly Option 403) is a standard feature for these switches. The serial number information below shows which switch units have the current interrupt function included as standard.

N1810UL: Serial numbers MY07244672 and later
N1810TL: Serial numbers MY07247927 and later
N1811TL: Serial numbers MY07244660 and later
N1812UL: Serial numbers MY07240668 and later

(3) Bracket kits apply to the L4490A/L4491A. The kits include pre-assembled control cables and hardware for mounting switches/attenuators to the brackets and the bracket assemblies to the chassis. Each bracket kit includes hardware for mounting five switches. The Y1173A kit allows you to mount up to six switches. The Cable (only) kits are primarily used with the 34945A/L4445A, but can also be used with the L4490A/L4491A. These cables must be assembled. Refer to Appendix A for cable assembly instructions.

Table 1-2. Recommended Accessories for Agilent Switches/Attenuators (Cont'd).

Attenuator Model	Reference Document Number ⁽¹⁾	Coil Voltage Option	Position Indicator Option	DC Connector Option	Distribution Board [number of attenuators per board]	Bracket Kit ⁽³⁾ [Cable Kit] ⁽³⁾
84904K - L 84906K - L 84907K - L	5963-6944E	24V (standard)	standard	10-pin DIP (standard)	Y1153A [2]	Y1174A [Y1158A]
84904M 84905M 84908M	5988-2475EN	024	standard	10-pin DIP (standard)	Y1153A [2]	Y1174A [Y1158A]
8494G - H 8495G - H 8496G - H 8495K 8497K	(4)	24V (standard)	standard	12-pin Viking (standard)	Y1153A [2]	Y1175A

(1) For product and technical overviews, go to <http://www.agilent.com/find/accessories>, select 'RF & Microwave Test Accessories'. Additional information can also be found in the "RF and Microwave Test Accessories Catalog" accessible from this site.

(3) Bracket kits apply to the L4490A/L4491A. The kits include pre-assembled control cables and hardware for mounting switches/attenuators to the brackets and the bracket assemblies to the chassis. Each bracket kit includes hardware for mounting five switches. The Y1173A kit allows you to mount up to six switches. The Cable (only) kits are primarily used with the 34945A/L4445A, but can also be used with the L4490A/L4491A. These cables must be assembled. Refer to Appendix A for cable assembly instructions.4445A, but can also be used with the L4490A and L4491A. These cables must be assembled. Refer to Appendix A for cable assembly instructions.

(4) Information on these attenuators plus additional information on the other attenuators can be found in the "RF and Microwave Test Accessories Catalog" accessible from this site.

Installing Switches/Attenuators in the RF Switch Platform

This section contains information on installing the switches and attenuators.

Removing the RF Platform Covers

Switch/attenuator installation and wiring requires removal of the top and bottom covers of the switch platforms, and for the L4491A, removal of the side panels as well.



Before removing the covers, disconnect the power cord from the instrument. The covers (and L4491A side panels) are removed by loosening the screw securing each cover and panel to the frame and sliding the cover/panel towards the back of the instrument. It is not necessary to remove the feet from the bottom cover.



CAUTION

Use care when handling the L4490A and L4491A chassis with the top and bottom covers removed as components within the chassis are susceptible to damage from ESD.

Figure 1-1 shows the location of the screws.

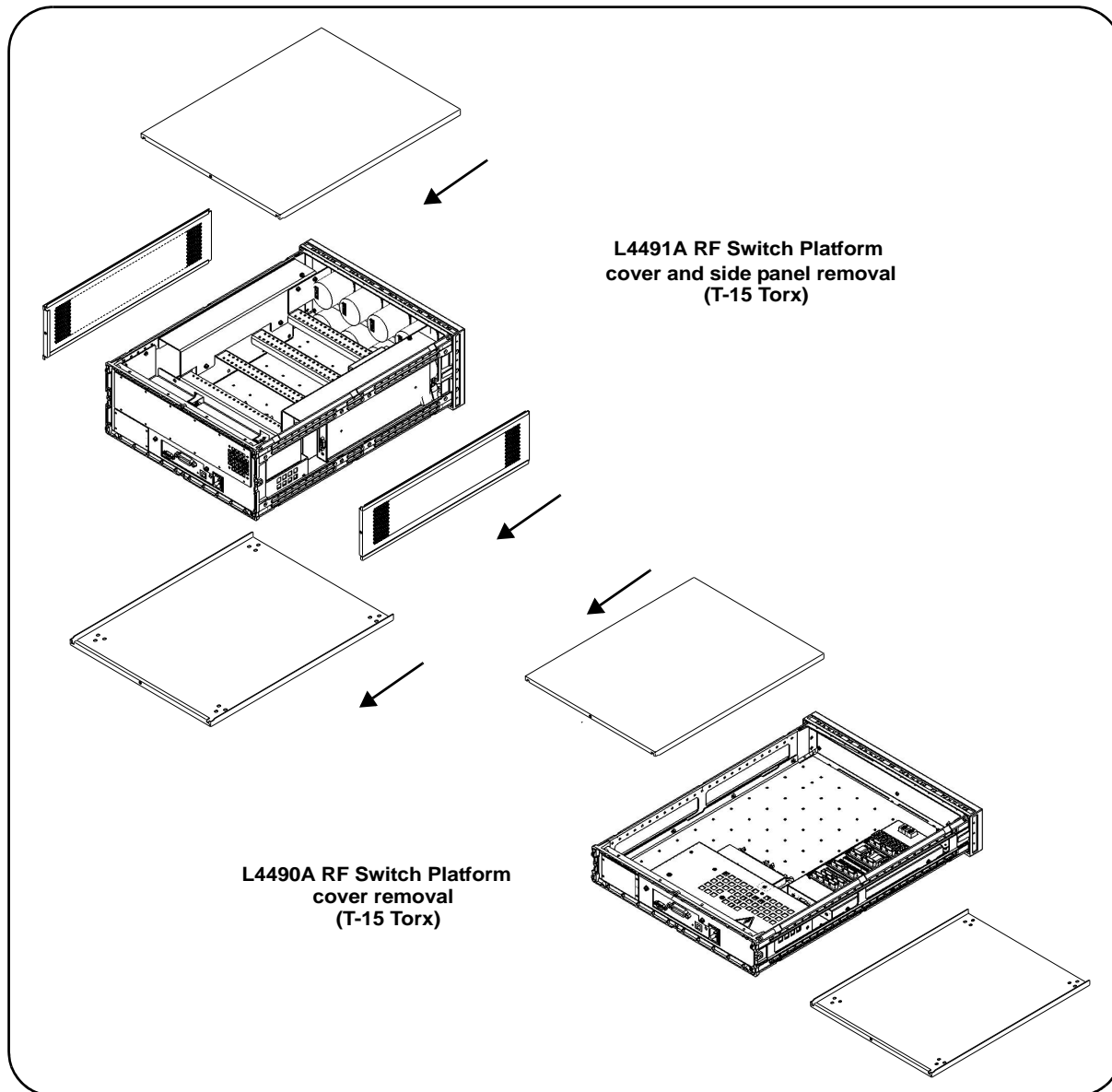

Figure 1-1. Removing the RF Platform Covers and Side Panels.

Bracket-Switch Assembly

Table 1-2 identifies the bracket kits (available separately) required to install the corresponding switches and attenuators in the RF switch platform. This section contains information on attaching the switch and attenuator to the bracket prior to installing the assembly in the platform.

Y1170A and Y1171A Brackets

Figure 1-2 shows the brackets contained in the Y1170A and Y1171A mounting kits and the mounting positions for the supported switches. The Y1170A bracket (kit) is required for the L4491A platform and the Y1171A bracket (kit) is required for the L4490A platform and the L4491A platform with Option 006.

The Y1170A and Y1171A kits contain hardware for installing five switches.

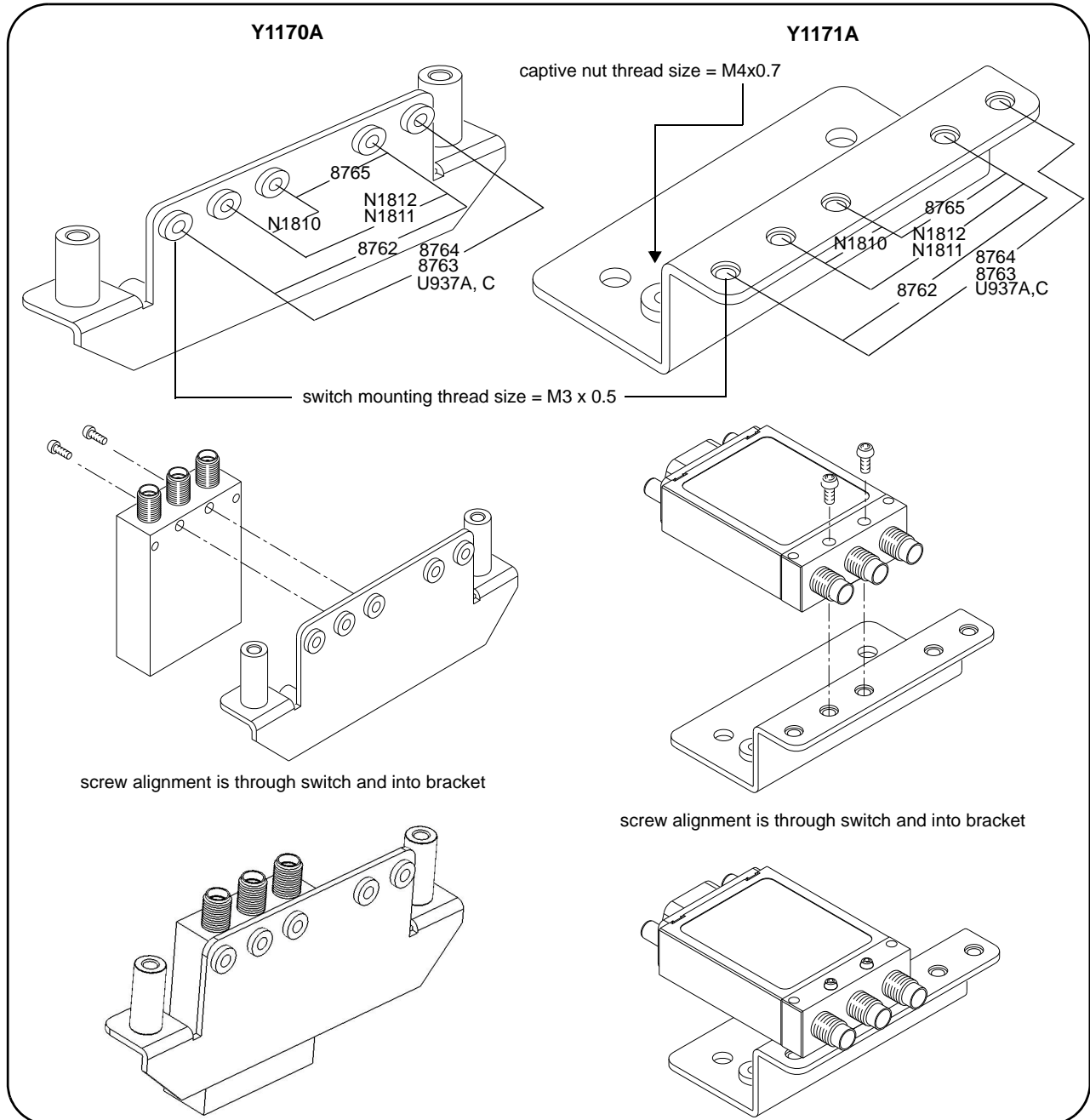

Figure 1-2. Connecting Switches to the Y1170A and Y1171A Brackets.

Y1172 Bracket

Figure 1-3 shows the bracket contained in the Y1172A mounting kit and the mounting position for the supported switches. The Y1172A bracket (kit) is used with both the L4490A and L4491A platforms.

The Y1172A kit contains hardware for installing five switches.

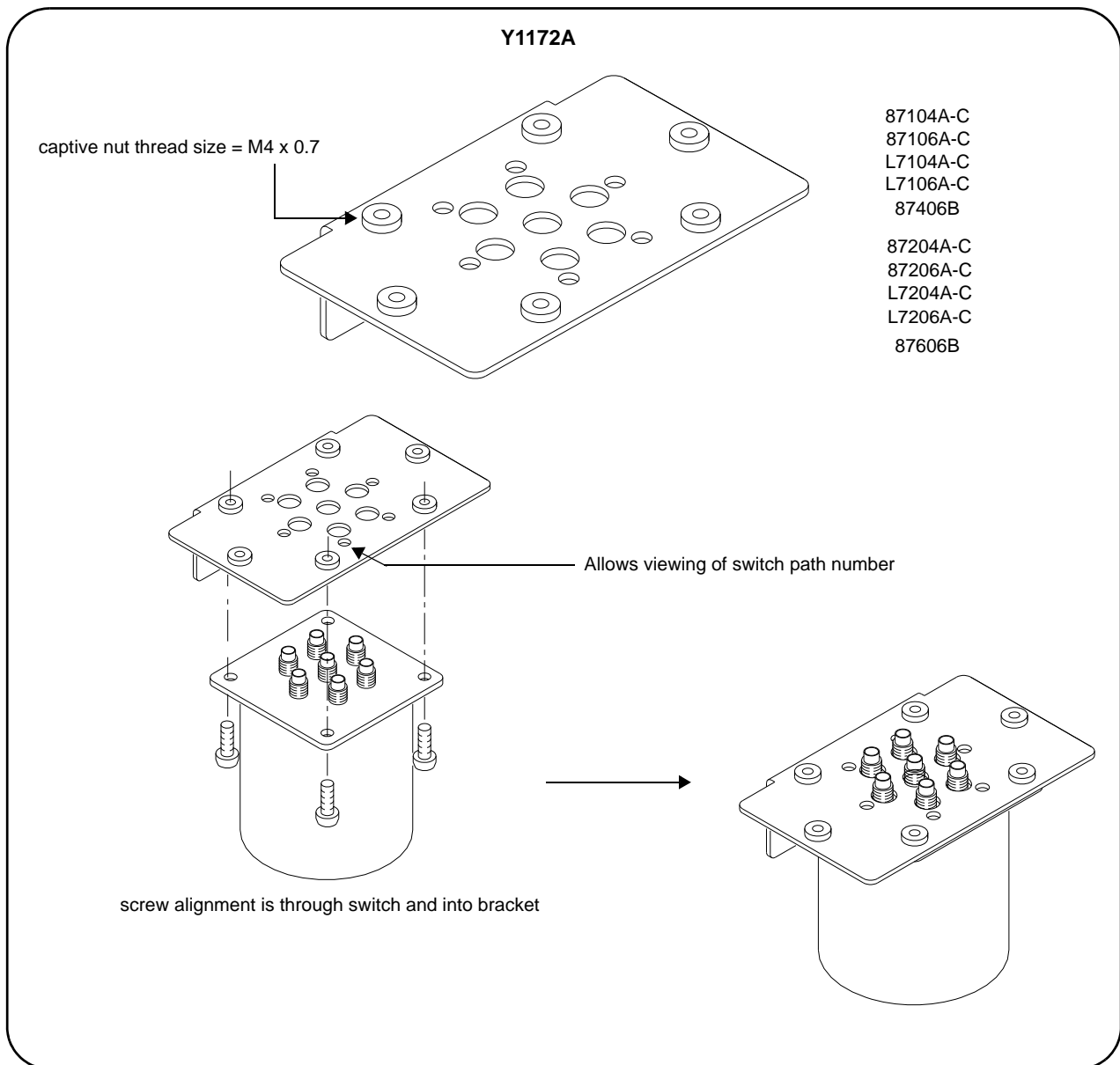

Figure 1-3. Connecting Switches to the Y1172A Bracket.

Y1173 Bracket

Figure 1-4 shows the bracket contained in the Y1173A mounting kit and the mounting position for the supported switches. The Y1173A bracket (kit) is used with both the L4490A and L4491A platforms.

The Y1173A kit contains hardware for installing six switches (two switches per bracket).

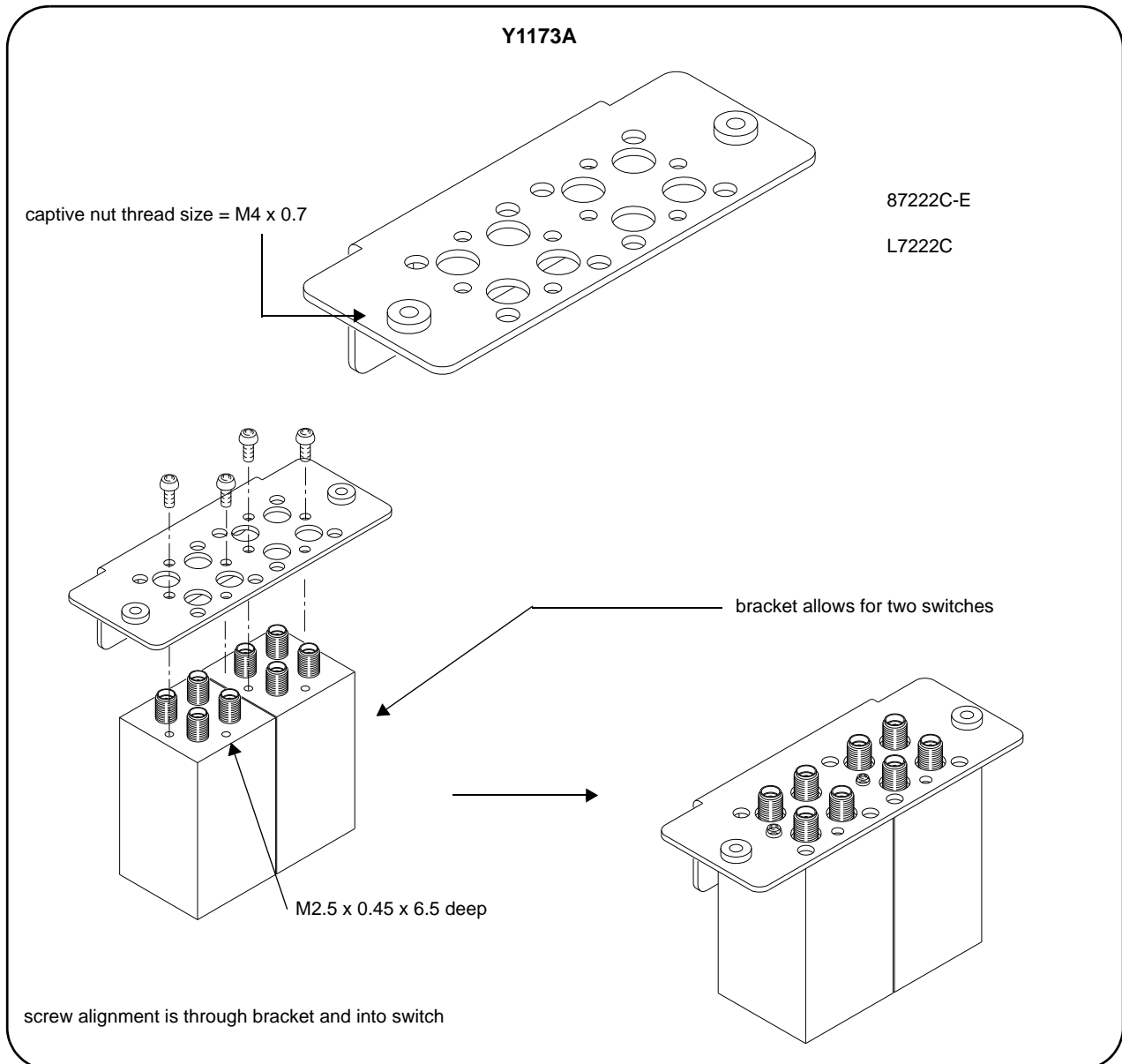

Figure 1-4. Connecting Switches to the Y1173A Bracket.

Y1174 Bracket

Figure 1-5 shows the bracket contained in the Y1174A mounting kit and the mounting positions for the supported attenuators. The Y1174A bracket (kit) is used with both the L4490A and L4491A platforms.

The Y1174A kit contains hardware for installing five attenuators.

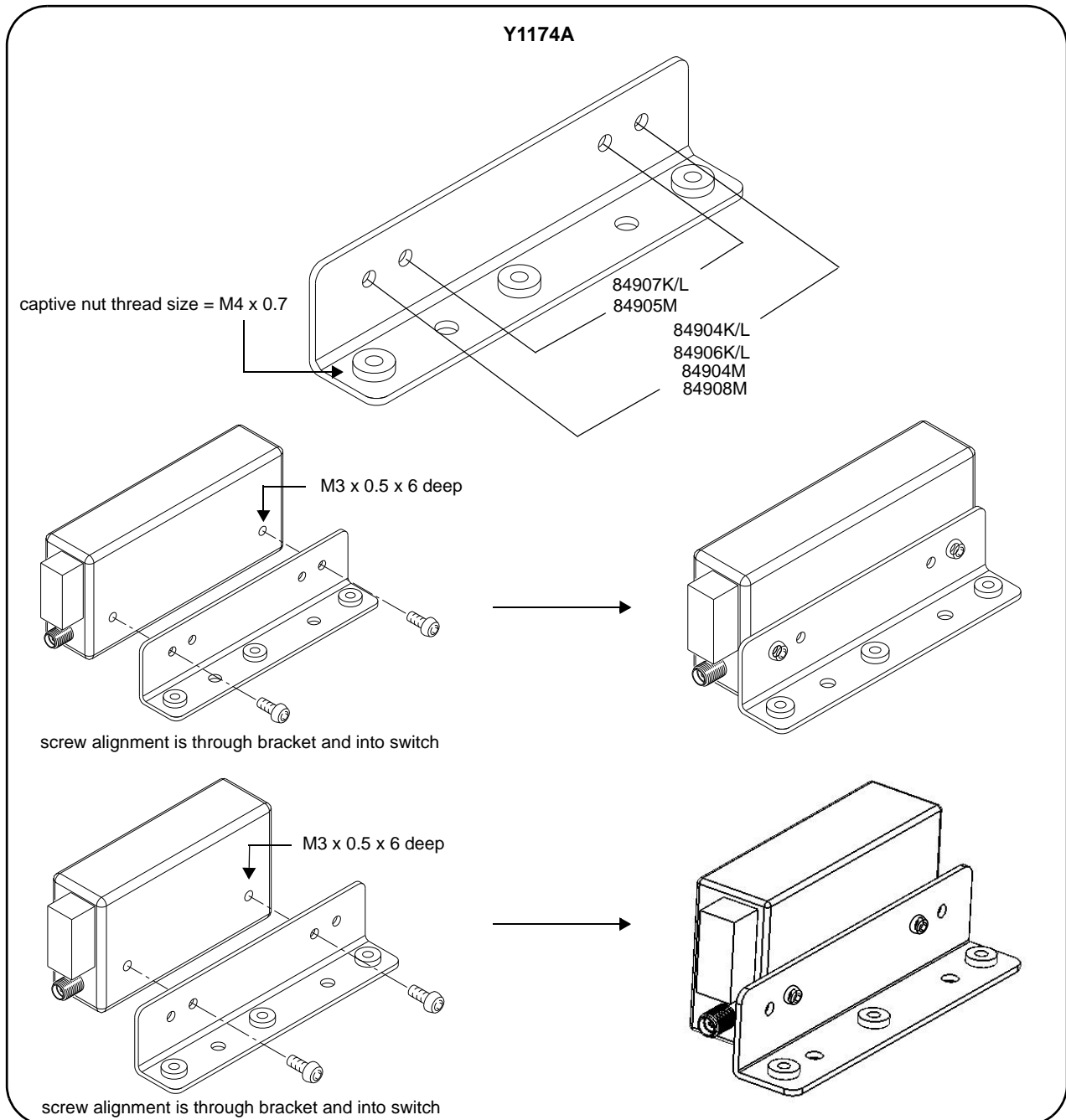

Figure 1-5. Connecting Switches to the Y1174A Bracket.

Y1175 Bracket

Figure 1-6 shows the bracket contained in the Y1175A mounting kit and the mounting positions for the supported switches and attenuators. The Y1175A bracket (kit) is used with both the L4490A and L4491A platforms.

The Y1175A kit contains hardware for installing five switches or attenuators.

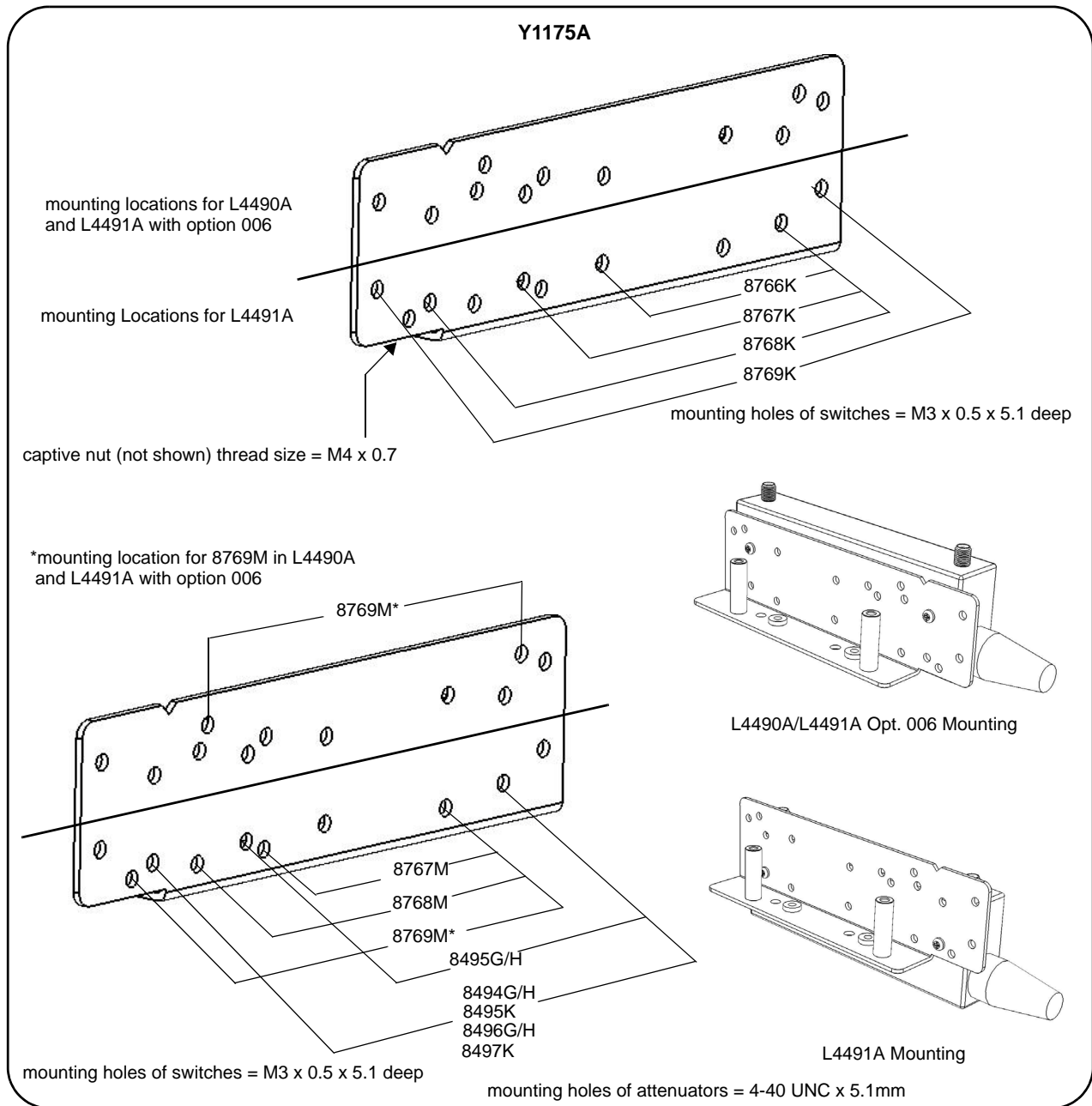

Figure 1-6. Connecting Switches to the Y1175A Bracket.

L4490A/L4491A Switch Trays and Options

The bracket-switch assemblies shown on the previous pages are mounted on the switch trays within the L4490A and L4491A switch platforms. The Y1170A - Y1175A bracket kits contain the required mounting hardware.

L4490A Switch Tray

Figure 1-7 shows the switch tray and bracket mounting location for the L4490A.

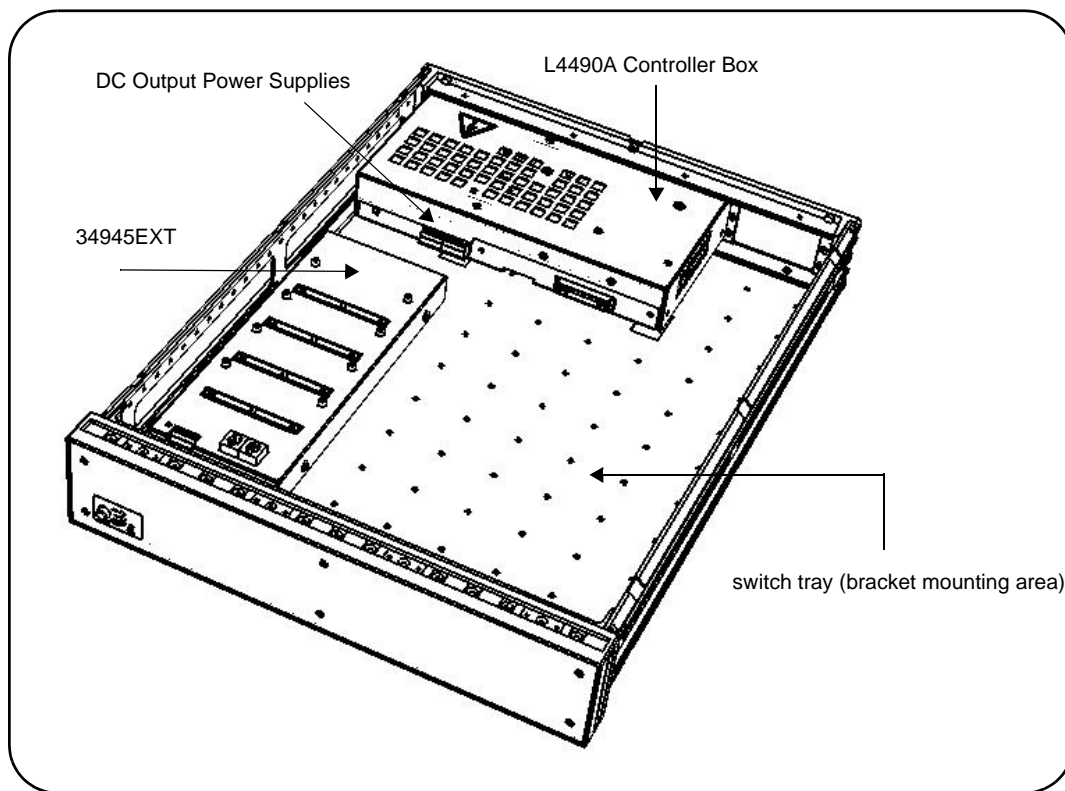

Figure 1-7. L4490A Bracket Mounting Locations.

The switch tray is a grid with spacings of 45.72 mm x 45.72 mm between any two holes in the 'x' and 'y' directions. Bracket mounting requires the L4490A top and bottom covers to be removed (Figure 1-1). Screw alignment is **upward** through the bottom of the tray and into the bracket's captive nut.

Figure 1-8 shows example placement of switches and attenuators within the L4490A.

NOTE

L4490A platforms with Digital IO and Relay Drive Option 004 reduces the tray area available for switch and attenuator installation.

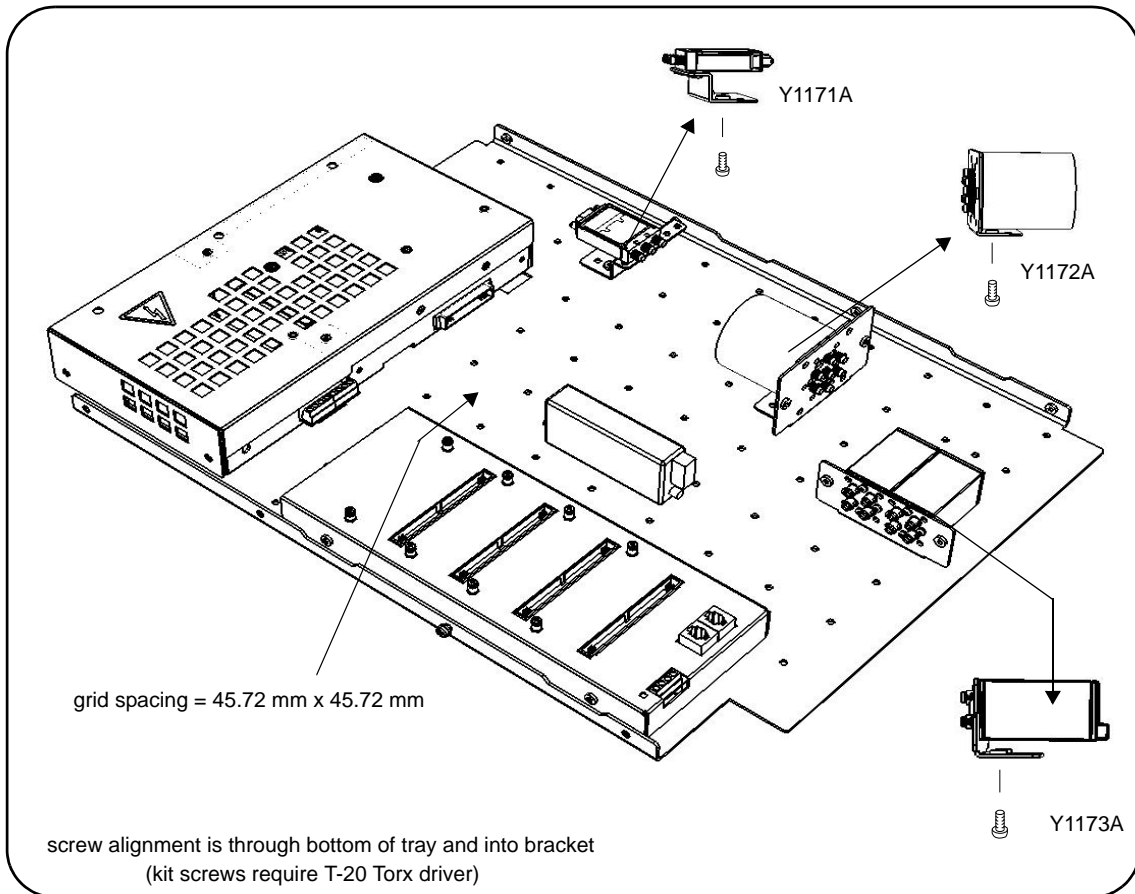

Figure 1-8. Example Switch and Attenuator Positioning within the L4490A.

L4491A Standard Mounting Bays (Option 005)

Figure 1-9 show the switch bays and bracket mounting locations for the L4491A with standard Option 005.

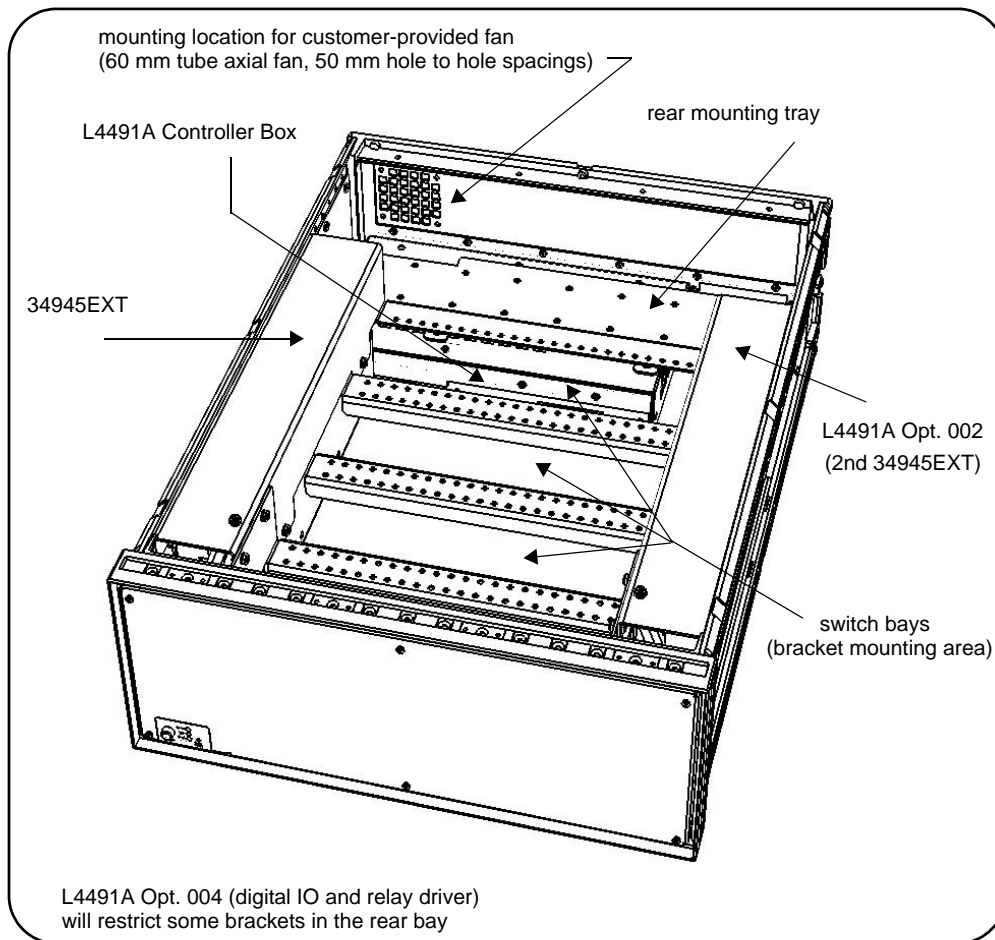

Figure 1-9. L4491A Standard Option 005 Bracket Mounting Locations.

Bracket mounting within the switch bays requires the L4491A top, bottom, and side covers to be removed (Figure 1-1). Screw alignment within the switch bays is **upward** through the bay rail and into the bracket's captive nut.

The rear mounting tray is a grid with spacings of 45.72 mm x 45.72 mm between any two holes in the 'x' and 'y' directions. Screw alignment in the rear mounting tray is **downward** through the bracket and into the captive nut on the tray.

Figure 1-10 shows example placement of switches and attenuators within the L4491A.

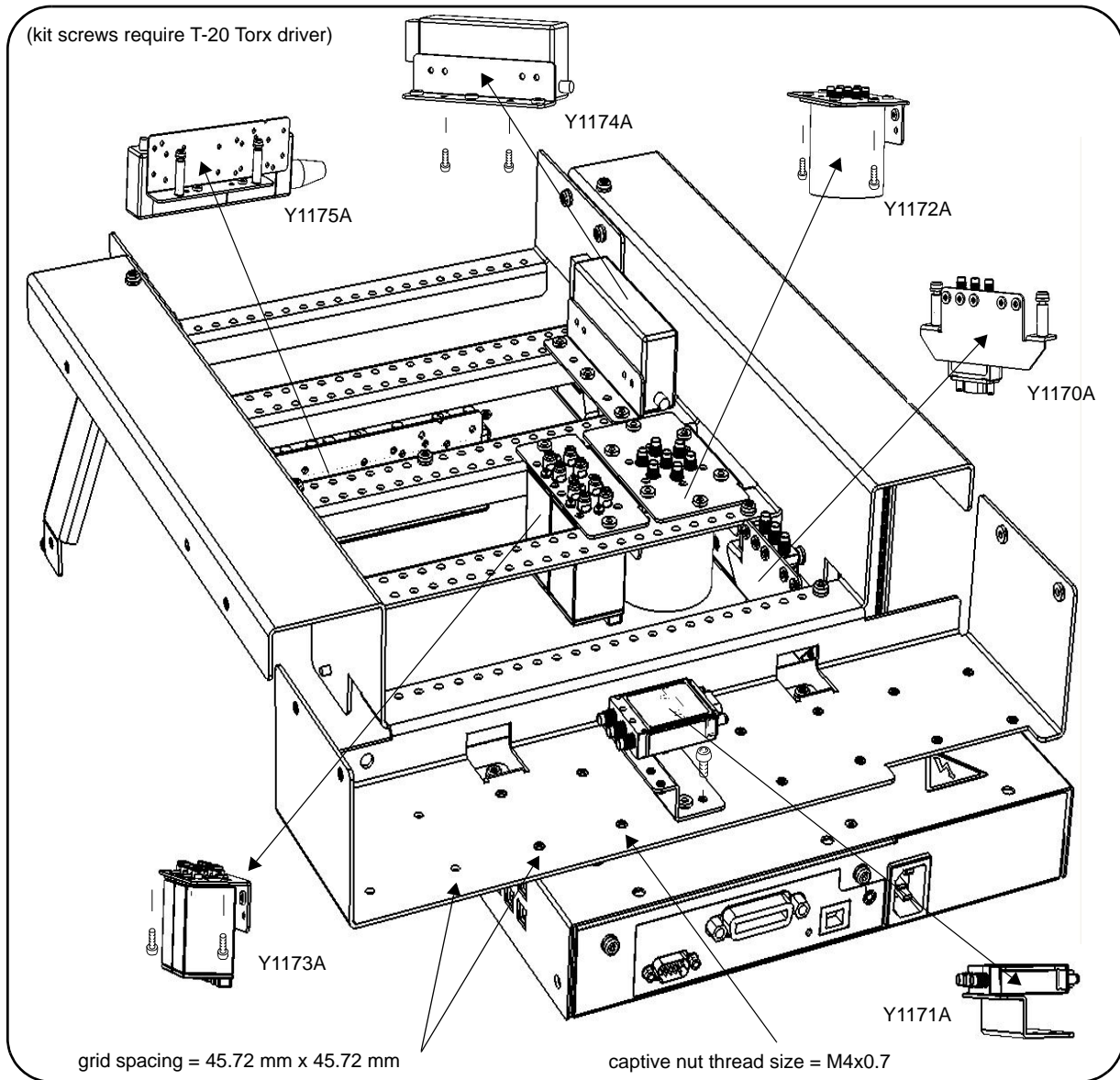

Figure 1-10. Example Switch and Attenuator Positioning: L4491A with Option 005.

L4491A Bottom Switch Tray (Option 006)

Figure 1-11 shows the switch tray and bracket mounting location for L4491A Option 006.

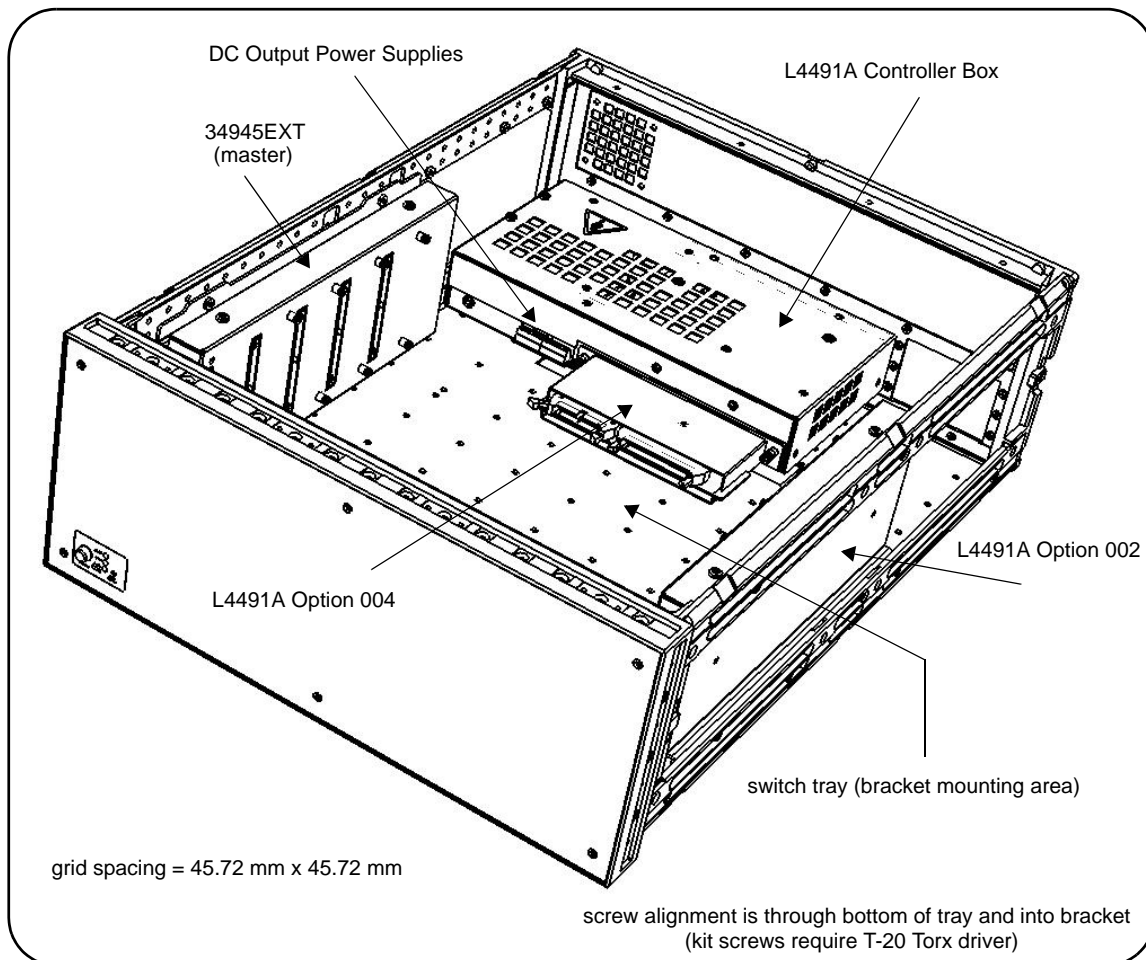

Figure 1-11. L4491A Bottom Switch Tray Option 006.

The switch tray is a grid with spacings of 45.72 mm x 45.72 mm between any two holes in the 'x' and 'y' directions. Bracket mounting with Option 006 requires the L4491A top, bottom, and side covers to be removed (Figure 1-1). Screw alignment is upward through the bottom of the tray and into the bracket's captive nut.

NOTE

L4491A Option 006 platforms without Digital IO and Relay Drive Option 004 will have a small increase in the bracket mounting area.

Example placement of switches and attenuators on the bottom tray is similar to those shown in Figure 1-7 for the L4490A.

L4491A Multiport Front Panel (Option 001)

Figure 1-12 shows L4491A multiport front panel Option 001. In order to use Option 001 with standard switch bay Option 005, the rail assembly behind the front panel must be removed. Figure 1-12 shows the assembly location and how it is removed.

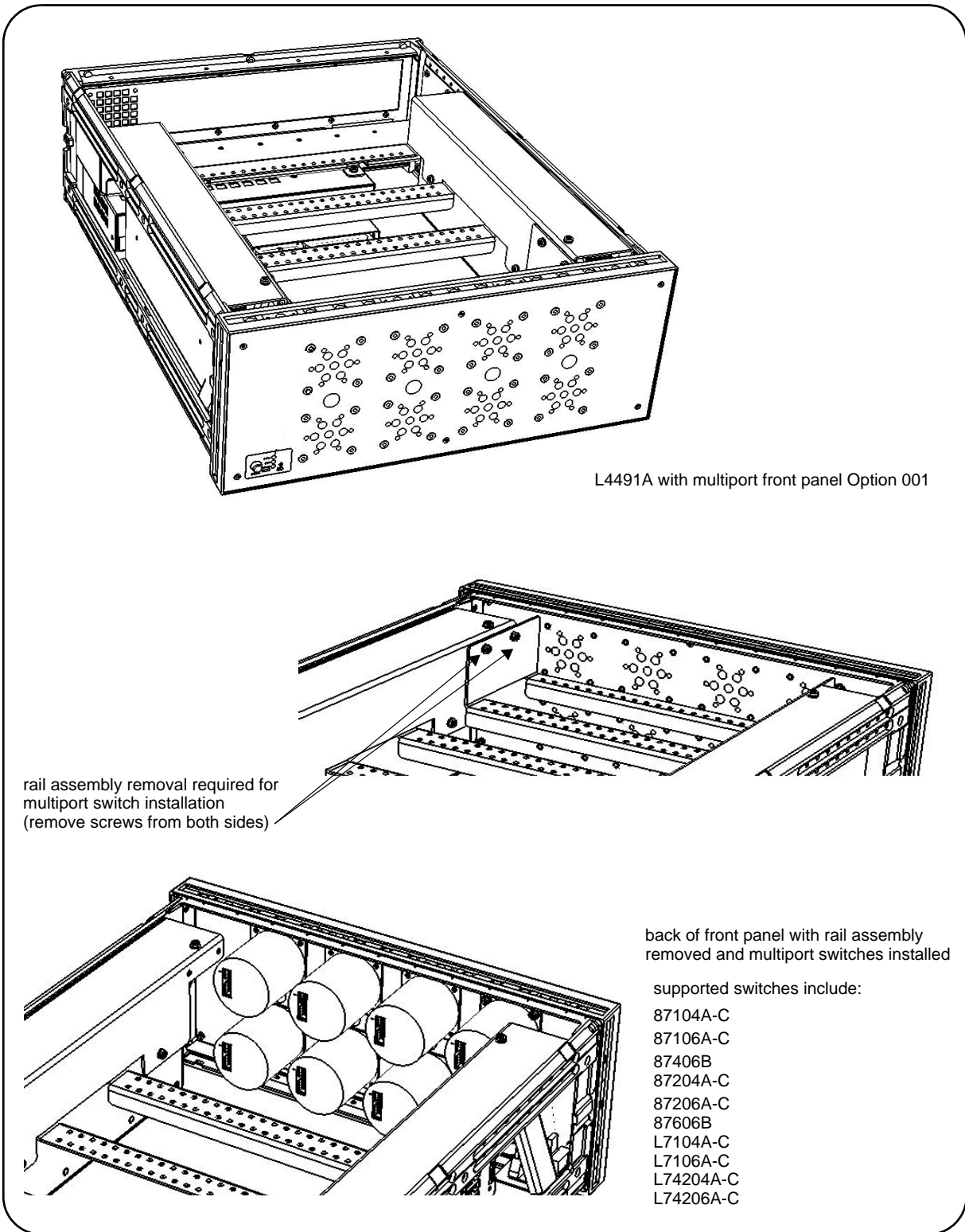

Figure 1-12. Multiport Front Panel Option 001 with Standard Bay Option 005.

L4490A/L4491A Bracket Layout Guidelines

Switches installed in the L4490A platform or in the L4491A platform with Option 006 can be mounted in any orientation that optimizes or simplifies switch or attenuator wiring.

For the L4491A with default Option 005, switches and attenuators may be mounted in any of the "bays" and in any combination. Figure 1-13 shows the typical number of given brackets (Y1170A - Y1175A) that can be installed in a bay.

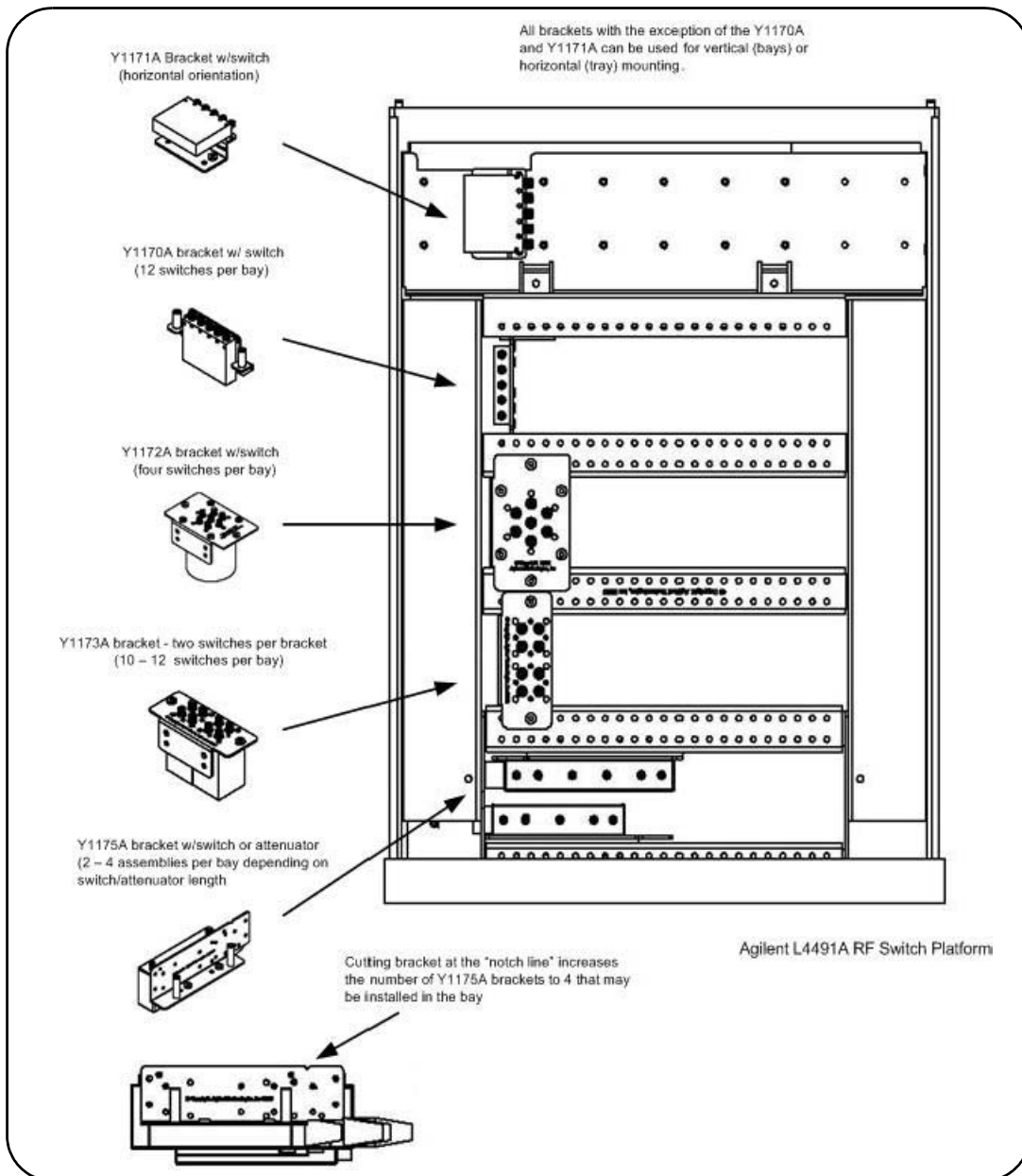
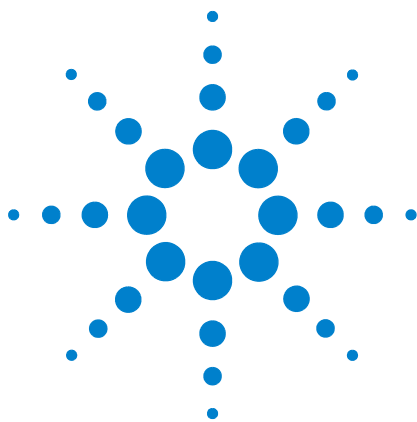

Figure 1-13. Bracket Layout Guidelines.



2 Hardware Configuration

Network Configuration	22
Selecting a LAN Network	22
Instrument Configuration	23
The 34945EXT Module	25
Channel Numbering	27
Internal/External Power Supply Considerations	28
Agilent Switch/Attenuator Configuration	31
Agilent N1810 / N1811 / N1812 Series Coaxial Switches	32
Agilent 87104/87106/87406 - L7104/L7106/L7204/L7206 Coaxial Switches	33
Agilent 87204 / 87206/ 87606 Series Coaxial Switches	34
Agilent 8767/8/9M Microwave Single-Pole Multi-Throw Switches	35
Agilent 84904/6/7 K/L and 84904/5/8M Programmable Step Attenuators	36
Agilent 8494/5/6/7 Programmable Step Attenuators	37
Agilent 849xG/H/K Programmable Step Attenuators Option 016	38
Agilent 87222 and L7222 Coaxial Switches	39
Agilent 8762 / 8763 / 8764 Series Coaxial Switches	40
Agilent 8765 Series Coaxial Switches	41
Agilent 8766/7/8/9K Microwave Single-Pole Multi-Throw Switches	42
Agilent U9397A / U9397C FET Solid State Switches	43

This chapter contains network, cabling, channel configuration, and switch wiring information for the L4490A/L4491A RF Switch Platform and supported switches/attenuators. Refer to this chapter for specific information on:

- choosing between a private LAN and site LAN network
- interconnections between the PC, RF switch platform, and the 34945EXT
- channel numbering and pairing
- internal/external power supply considerations
- connecting switches and attenuators to the distribution boards



Network Configuration

This section contains information for choosing a network configuration (a private or site LAN) in which to use the L4490A/L4491A.

Selecting a LAN Network

For the purposes of this manual, a private (isolated) LAN network is defined as a network configuration in which instrument access is a direct connection between the computer and the instrument, or to multiple instruments connected via a *dedicated* router or switch. A site (company-wide) LAN is defined as a network in which instrument access is available to many users at on-site and remote locations.

The instrument's application and/or your company's IT (Information Technology) department may have guidelines that help decide the type of network (private or site) used. If a network configuration has not been determined, refer to the following considerations concerning each type.

Private LAN Considerations

Among the basic parameters of a private LAN network to consider are security, performance, reliability, and IP address availability.

Security: a private network generally involves a direct connection between the PC and the instrument, or to multiple instruments using switches or routers. Access to the instrument is limited to users on the private network, as opposed to users on a site network that could locate and access the instrument from any location. Private networks can reduce the possibility of tests being disrupted by unplanned or unauthorized access. Code generation for test systems on a private network is often simplified as provisions against unauthorized users may not be required.

Performance: test systems where large amounts of data are transferred usually have faster throughput on a private network. On a site network, heavy and unpredictable LAN traffic affects each instrument (node) on the network. The impact on a test system is that repeatability is difficult to achieve as latencies are difficult to account for.

Reliability: private networks are fundamentally more reliable than site networks as they host fewer users and are less complex than site networks. Private networks are isolated from conditions that could bring down (crash) a site network.

IP Address Availability: Every instrument (node) on a LAN (private or site) has an IP (Internet Protocol) address. Due to the expanding use of the internet, the number of site network IP addresses available is limited. By using a router with Dynamic Host Configuration Protocol (DHCP) capability on a private network, the router can assign an IP address to each instrument thus creating a sub-network (subnet) that does not consume site IP addresses.

Site LAN Considerations

For applications requiring access by many users or by users at distributed sites, a site LAN network is required. In addition to supporting multiple users, site LANs often offer the advantage of being maintained by IT departments.

When using a site LAN, consult your IT department regarding LAN configuration and security issues.

Instrument Configuration

Figure 2-1 shows the components and interconnections of the L4490A/L4491A RF switch platform configuration.

2 Hardware Configuration

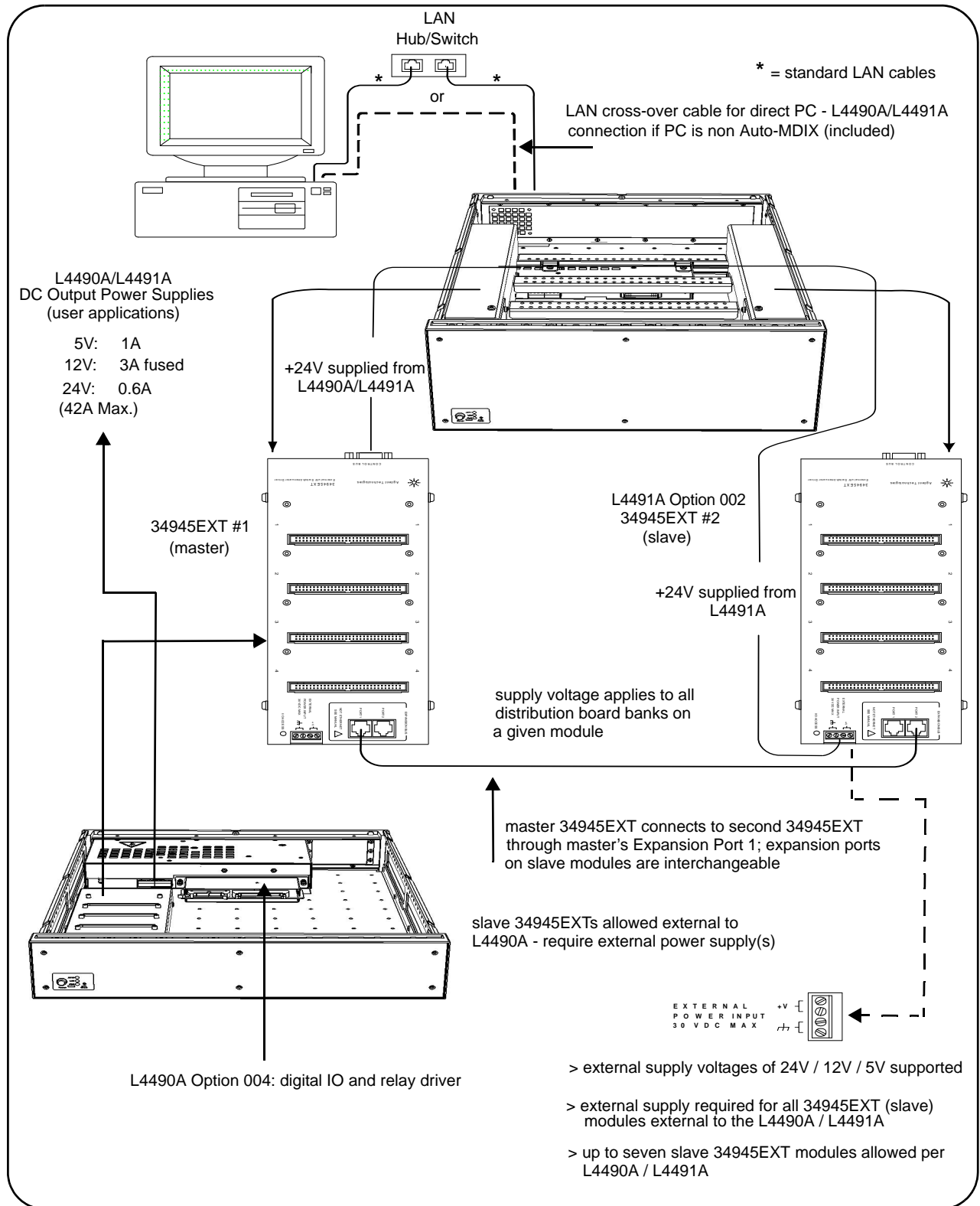

Figure 2-1. L4490A/L4491A RF Switch Platform Configuration.

PC to L4490A/L4491A. When connecting the PC **directly** to the L4490A/L4491A, the LAN cross-over cable provided with the L4490A/L4491A is used. If your PC supports Auto-MDIX or contains a LAN card with Gigabit data transfer rates, the cross-over cable is not required. A standard LAN cable may be used instead.

For network configurations (private or site) that include a LAN switch or router between the PC and L4490A/L4491A, standard LAN cables are used. **Do not use the cross-over cable.**

L4490A/L4491A to 34945EXT. The L4490A/L4491A controller box is connected directly to the master 34945EXT and also to the second (slave) 34945EXT if installed in the L4491A (Option 002). +24V is supplied through this connection. An external supply can also be used with the 34945EXTs for applications requiring increased switching capacity.

34945EXT to 34945EXT. L4491A Option 002 adds a second (slave) 34945EXT module. The second 34945EXT comes connected within the L4491A chassis to the master 34945EXT using a standard LAN cable between the master's Expansion Bus Port 1 and Expansion Port 2 of the second EXT module. (The ports of all slave 34945EXTs are interchangeable.) Up to eight 34945EXT modules (including the master) can be used per L4490A or L4491A.

34945EXT to External Power Supplies. All slave 34945EXT modules **external** to the L4490A or L4491A chassis **must** use an external power supply or supplies. Note that the supply voltage (+24V, +12V, +5V) applies to all distribution board banks on the 34945EXT.

The 34945EXT Module

Microwave switches and attenuators are connected to the L4490A/L4491A configuration through distribution boards (Y1150A - Y1155A) installed on the 34945EXT module (Figure 2-2).

The 34945EXT is divided into four banks organized by channel number. Any distribution board may be installed in any bank, and multiple distribution boards of the same type may be installed on the same 34945EXT module. **Distribution boards can be installed or removed with the L4490A/L4491A turned on; however, the channel drive source (Figures 4-2, 4-3) must be off.**

The "I/O ACCESS" LED on the EXT module indicates communication sequences between the L4490A/L4491A controller box and the 34945EXT.

The Y1156A Verification Board

The optional Y1156A Verification board (not shown) is used to verify the signal path from the PC to banks 1-4 on the 34945EXT. Verification of the path is recommended before connecting switches or attenuators to the distribution boards, or if a problem is suspected. See Chapter 4 for more information.

2 Hardware Configuration

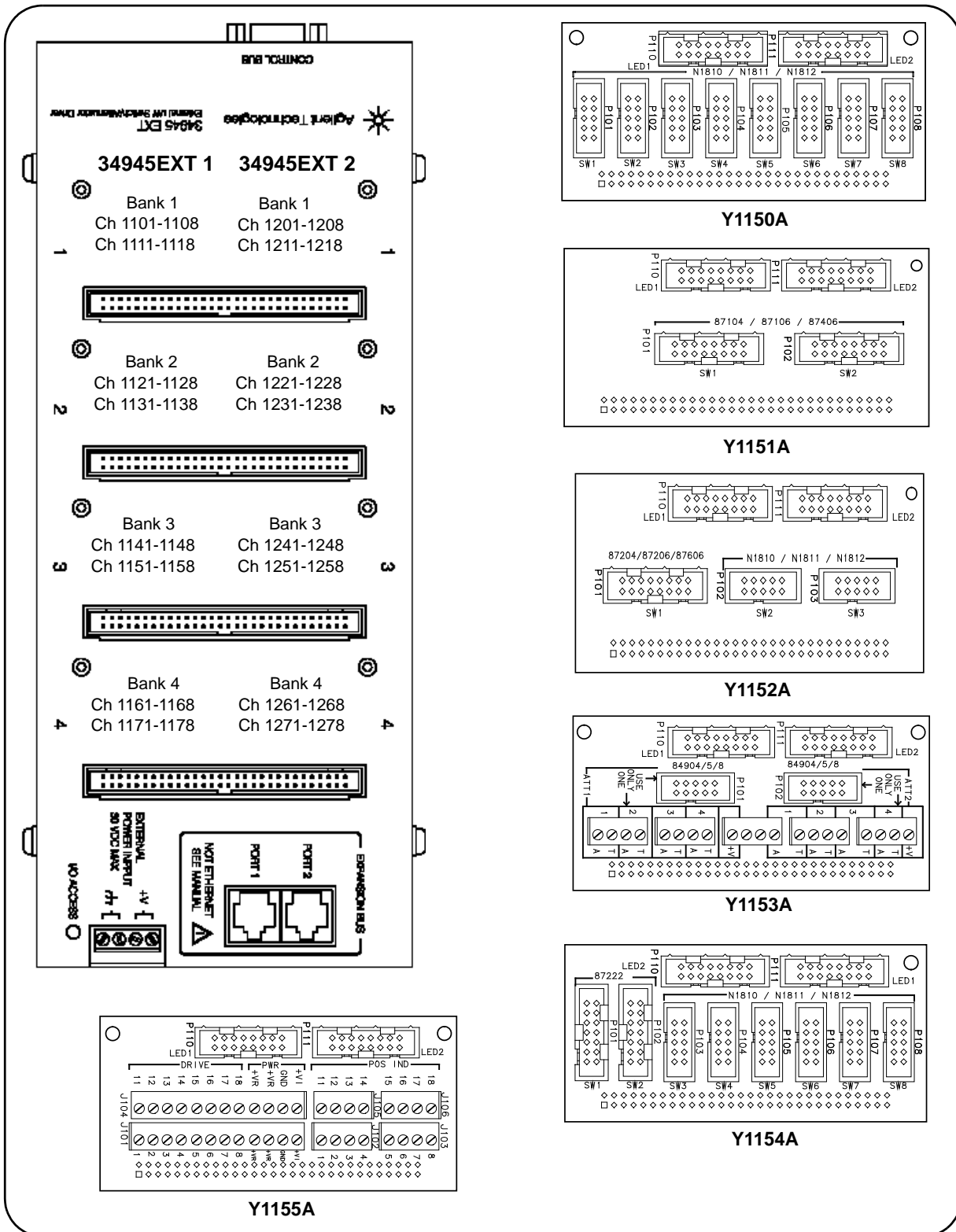

Figure 2-2. The 34945EXT Module and Y1150A-Y1155A Distribution Boards.

Channel Numbering

The 34945EXT in the L4490A/L4491A RF switch platform uses the following channel numbering scheme:

`1<ext #><channel>`

where:

ext # is the 34945EXT module and is a single digit in the range of 1 (master) to 2 (slave - a second 34945EXT in the L4491A). Note that up to seven slave EXT modules may be used per master 34945EXT in the L4490A/L4491A.

channel is the channel number in the specified EXT module bank.

Channel numbers for two 34945EXT modules are shown in Figure 2-2 and also in the table below.

34945EXT #1 (Master)			34945EXT #2 (Slave)		
Bank	Channels	Channels	Bank	Channels	Channels
Bank 1	1101 to 1108	1111 to 1118	Bank 1	1201 to 1208	1211 to 1218
Bank 2	1121 to 1128	1131 to 1138	Bank 2	1221 to 1228	1231 to 1238
Bank 3	1141 to 1148	1151 to 1158	Bank 3	1241 to 1248	1251 to 1258
Bank 4	1161 to 1168	1171 to 1178	Bank 4	1261 to 1268	1271 to 1278

An example of this syntax is:

```
ROUT:CLOS (@1141)
```

which closes channel 41 (bank 3) on 34945EXT module number 1 (Figure 2-1).

A range of channels is specified as:

```
ROUT:CLOS (@1101:1138)
```

which in this example closes channels 1 (bank 1) through 38 (bank 2) on 34945EXT module number 1 (channel ranges can extend across banks).

Module- and Bank-Level Commands

Selected commands within the L4490A/L4491A SCPI command set contain parameters that specify the 34945EXT itself, or a bank on the 34945EXT rather than a channel list. These commands include:

```
ROUTe:RMOdule:BAnt:DRIVE:MODE
ROUTe:RMOdule:BAnt:LED:DRIVE:ENABle
ROUTe:RMOdule:BAnt:LED:DRIVE:LEVel
ROUTe:RMOdule:BAnt:PRESet
ROUTe:RMOdule:DRIVE:LIMit
ROUTe:RMOdule:DRIVE:SOURce:BOOT
ROUTe:RMOdule:DRIVE:SOURce:IMMediate
```

For these commands, the 34945EXT address is in the form:

```
1<ext #><00>
```

where:

ext # is the 34945EXT module and is a single digit in the range of 1 (master) to 2 (a 2nd (slave) 34945EXT in the L4491A). For example,

```
ROUT:RMOD:BANK:PRES 2, (@1200)
```

presets bank 2 on 34945EXT module 2.

Relay/Channel Relationship

The Agilent switches and attenuators listed in Table 1-2 are latching relays. Therefore, there is a relay coil for each switch or attenuator position. In the factory default configuration (SYSTEM:RModule:RESet 1), **a distribution board channel is assigned to each relay coil**. There are 16 channels per distribution board.

Channel Pairing

Channel numbers on the distribution boards are arranged to facilitate channel pairing for dual-coil switches and attenuators. In paired configurations, channels 1-8 are paired with 11-18 (bank 1), 21-28 with 31-38 (bank 2), 41-48 with 51-58 (bank 3), and 61-68 with 71-78 (bank 4). Paired channels are controlled by a single command (e.g. OPEN or CLOSE) in which only the **lower** channel of the pair is specified. When a command (OPEN or CLOSE) is sent, the operation sends a drive pulse to either the first or second channel in the pair - either opening or closing the channel.

For the channel pair 1/11, the following syntax:

```
ROUT:CLOS (@1101) - sends a drive pulse to the upper channel (1111)
```

```
ROUT:OPEN (@1101) - sends a drive pulse to the lower channel (1101)
```

Non-Paired Channels

When channel pairing is not enabled (e.g. for single-coil drive), the channel numbers within the bank are not consecutive. The range of the 16 channels remains 1-8/11-18 (bank 1) ... 61-68/71-78 (bank 4). See the previous page.

Internal/External Power Supply Considerations

As shown in Figure 2-1, the channel drive source for switches and attenuators in the L4490A/L4491A RF Switch Platform is provided through the internal (or external) power supply. The internal or external supply used must meet the quiescent (steady-state) and switching current

requirements of the switches in your application. The following sections provide additional information on these requirements and the recommended configuration of these supplies.

Internal Supply

The master 34945EXT (Figure 2-1) and optional second 34945EXT (Option 002) can receive their power from either the internal +24V supply of the L4490A/L4491A or from an external supply. When using the internal +24V supply as the channel drive source, the switching current or the switching and quiescent currents drawn from the supply must not exceed the supply's specification of 600 mA continuous.

If this limit is exceeded, an overcurrent condition can occur which shuts down the internal supply. When this happens, you must remove the device/condition causing the overcurrent and cycle power on the L4490A or L4491A. See "Overcurrent Conditions" in Chapter 5 for more information.

The quiescent current of 34945EXTs driven by the internal supply is accounted for by the supply rating and is not included in quiescent current and switching current calculations. Only the specified currents (quiescent, switching) of the **switch** must be considered.

As an example, the Agilent 87104/87106A, B, C coaxial switches specify the following:

Supply current (switching: pulse width =15 ms:Vcc = 24 VDC): **200 mA** Nom

Supply current (quiescent): **50 mA** Max

Using the L4490A/L4491A internal +24V supply, the current required for actuating a 87104/87106 switch is:

$$\begin{aligned}
 & \text{[87104 / 87106 switch quiescent current]} + \text{[87104 / 87106 switching current]} \\
 & \qquad \qquad \qquad \text{[50 mA]} \qquad \qquad \qquad + \qquad \qquad \qquad \text{[200 mA]} \\
 & = \text{250 mA} \quad (15 \text{ ms pulse, } 50 \text{ mA quiescent})
 \end{aligned}$$

CAUTION

The combination of switches and their power requirements often make it difficult to determine if the capacity of the L4490A and L4491A internal +24V supply will be exceeded. If overcurrent conditions occur repeatedly regardless of recovery time (Chapter 5), the use of an external power supply as the channel drive source may be required.

External Supply

Each 34945EXT can support up to 2A continuous using an externally connected power supply (4.75V to 30V). The actual amount of power required by each EXT module depends on the types of switches used.

When using an external power supply with either the master 34945EXT module or second (slave) 34945EXT module or both, the supply must be able to provide the quiescent current requirement of the EXT module(s), plus the quiescent and switching currents of the switches themselves.

The power requirement of the 34945EXT is 1.2W. For supported external supply voltages of 24V, 12V, and 5V, the current required for a single EXT module is as follows:

current = power / voltage

24V: $1.2\text{W} / 24\text{V} = 50 \text{ mA}$

12V: $1.2\text{W} / 12\text{V} = 100 \text{ mA}$

5V: $1.2\text{W} / 5\text{V} = 240 \text{ mA}$

If multiple EXT modules are driven by a single external supply, the power required from the supply increases by 1.2W for each EXT module present. Thus, if two 34945EXT modules are driven by a single supply, the power value in the previous equations becomes 2.4W.

The second consideration regarding the external supply are the quiescent current and switching current specifications of the switch. Using the Agilent 87104/87106A, B, C coaxial switches from the internal supply example, the switch specifications again are:

Supply current (switching: pulse width =15 ms:Vcc = 24 VDC): **200 mA** Nom

Supply current (quiescent): **50 mA** Max

The quiescent current required when switching does not occur is:

[34945EXT quiescent current from 24V] + [87104 / 87106 switch quiescent current]

[24V: $1.2\text{W} / 24\text{V} = 50 \text{ mA}$] + [50 mA] = **100 mA**

For a single 34945EXT driven by an external supply, the current required for actuating a 87104/87106 switch is:

[34945EXT quiescent current from 24V] + [switch quiescent current] + [switching current]

[24V: $1.2\text{W} / 24\text{V} = 50 \text{ mA}$] + [50 mA] + [200 mA] = **300 mA** (15 ms pulse, 100 mA qui.)

In summary, quiescent current calculations must include the quiescent current of the 34945EXT, plus the quiescent current requirement of **each** switch connected to the module.

Similarly, switching current calculations must include the quiescent currents of the EXT module and the switch, plus the switching (actuation pulse) current.

Agilent Switch/Attenuator Configuration

This section contains pin definitions and orientation to assist in connecting the Agilent switches/attenuators listed in Table 1-2 to their corresponding Y115x distribution boards.

Only general information is provided. Refer to the reference documents listed in Table 1-2 for more information on the individual switches. Refer also to Table 1-2 for the number of switches allowed per distribution board.

Agilent N1810 / N1811 / N1812 Series Coaxial Switches

Figure 2-3 shows the pin definitions and orientation for the Y1150A, Y1152A, and Y1154A distribution board connectors and the Agilent N181x series switches.

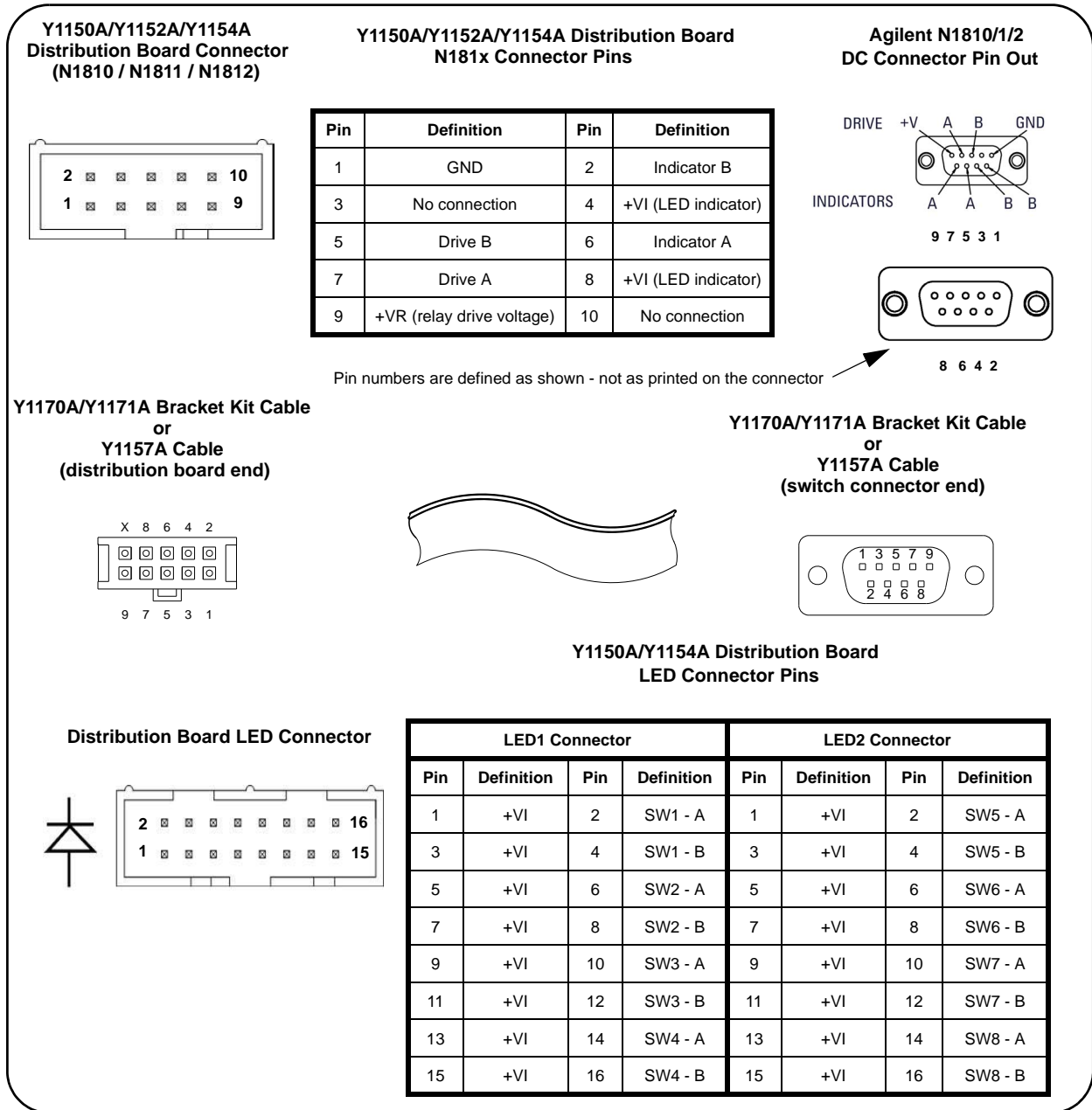

Figure 2-3. Agilent N1810 / N1811 / N1812 Pin Definition and Orientation.

NOTE

The pin information for the Agilent switches shown in Figure 2-3 was taken from the reference documents listed in Table 1-2. Refer to Table 1-2 for information on accessing these documents from the Agilent web-site.

Agilent 87104/87106/87406 - L7104/L7106/L7204/L7206 Coaxial Switches

Figure 2-4 shows the pin definitions and orientation for the Y1151A distribution board, the Agilent 87104, 87106, and 87406 series switches, and the L7104, L7106, L7204, and L7206 L series switches.

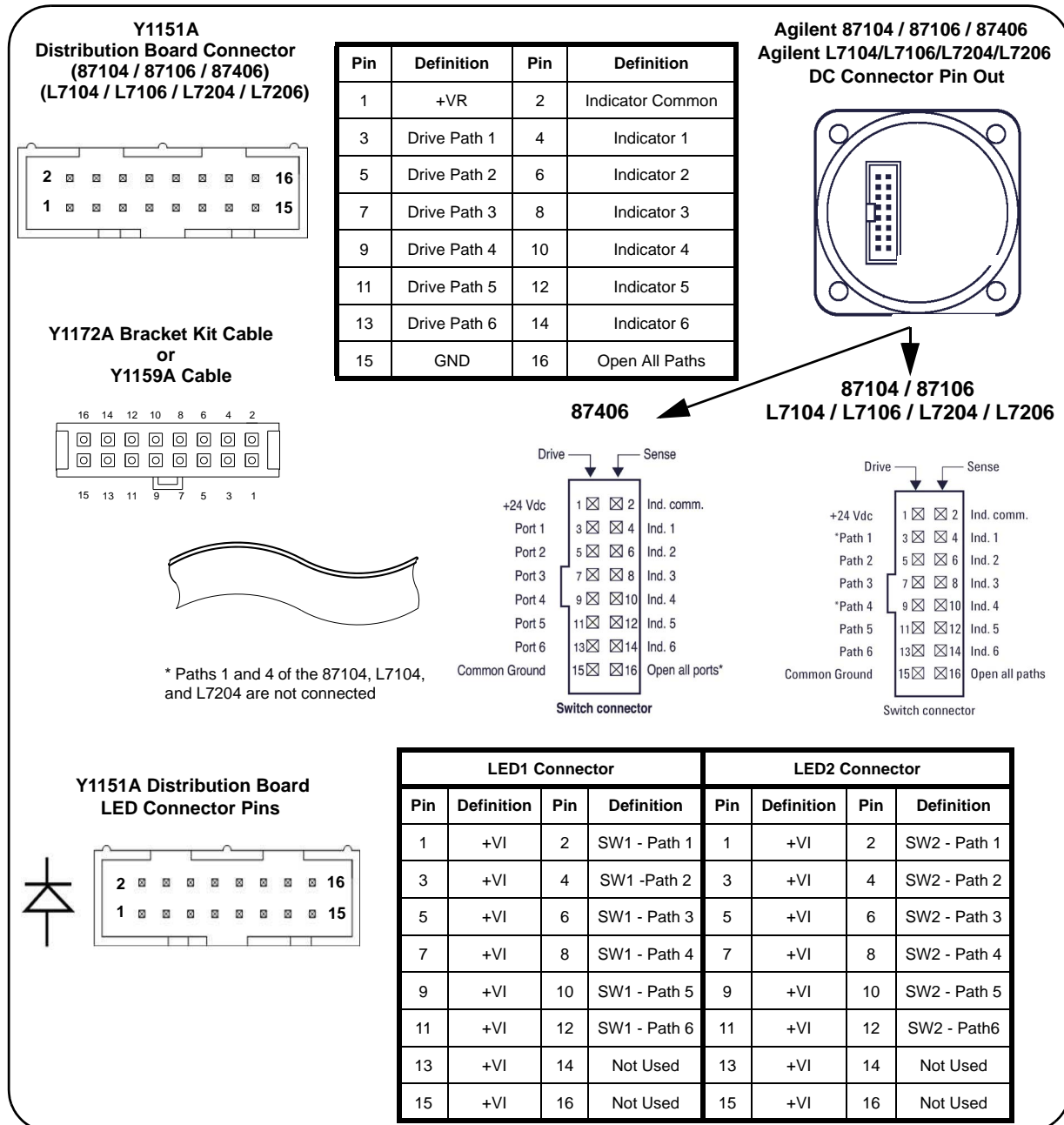

Figure 2-4. Agilent 871x / 874x / L71x / L72x Pin Definition and Orientation.

NOTE

The pin information for the Agilent switches shown in Figure 2-4 was taken from the reference documents listed in Table 1-2. Refer to Table 1-2 for information on accessing these documents from the Agilent web-site.

Agilent 87204 / 87206 / 87606 Series Coaxial Switches

Figure 2-5 shows pin definitions and orientation for the Agilent Y1152A distribution board and the 87204, 87206, and 87606 series switches.

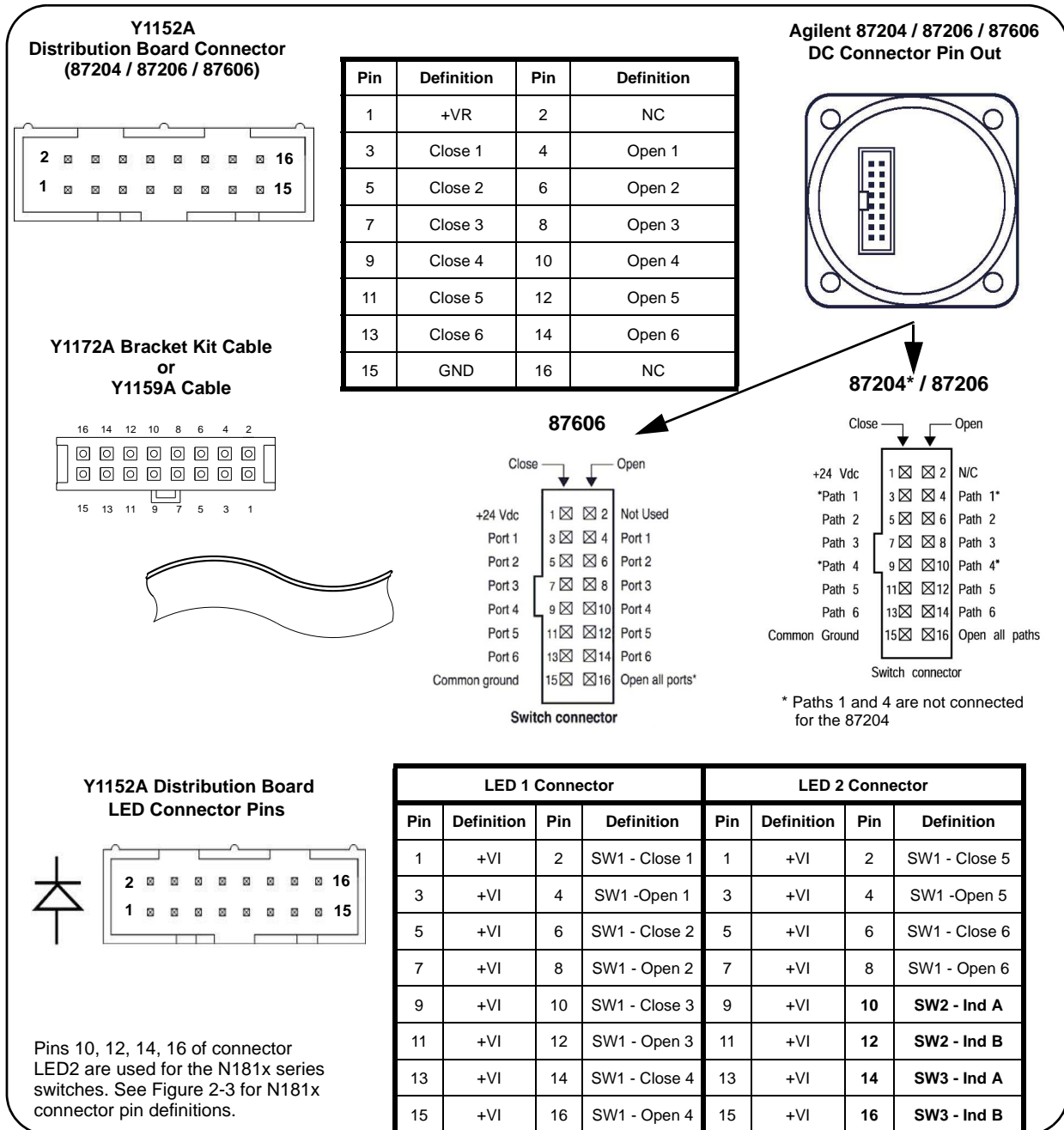

Figure 2-5 Agilent 87204 / 87206 / 87606 Pin Definition and Orientation.

NOTE

The pin information for the Agilent switches shown in Figure 2-5 was taken from the reference documents listed in Table 1-2. Refer to Table 1-2 for information on accessing these documents from the Agilent web-site.

Agilent 8767/8/9M Microwave Single-Pole Multi-Throw Switches

Figure 2-6 identifies the terminals of the 8767/8/9M switches and typical connections to the Y1153A distribution board (* 8767M shown).

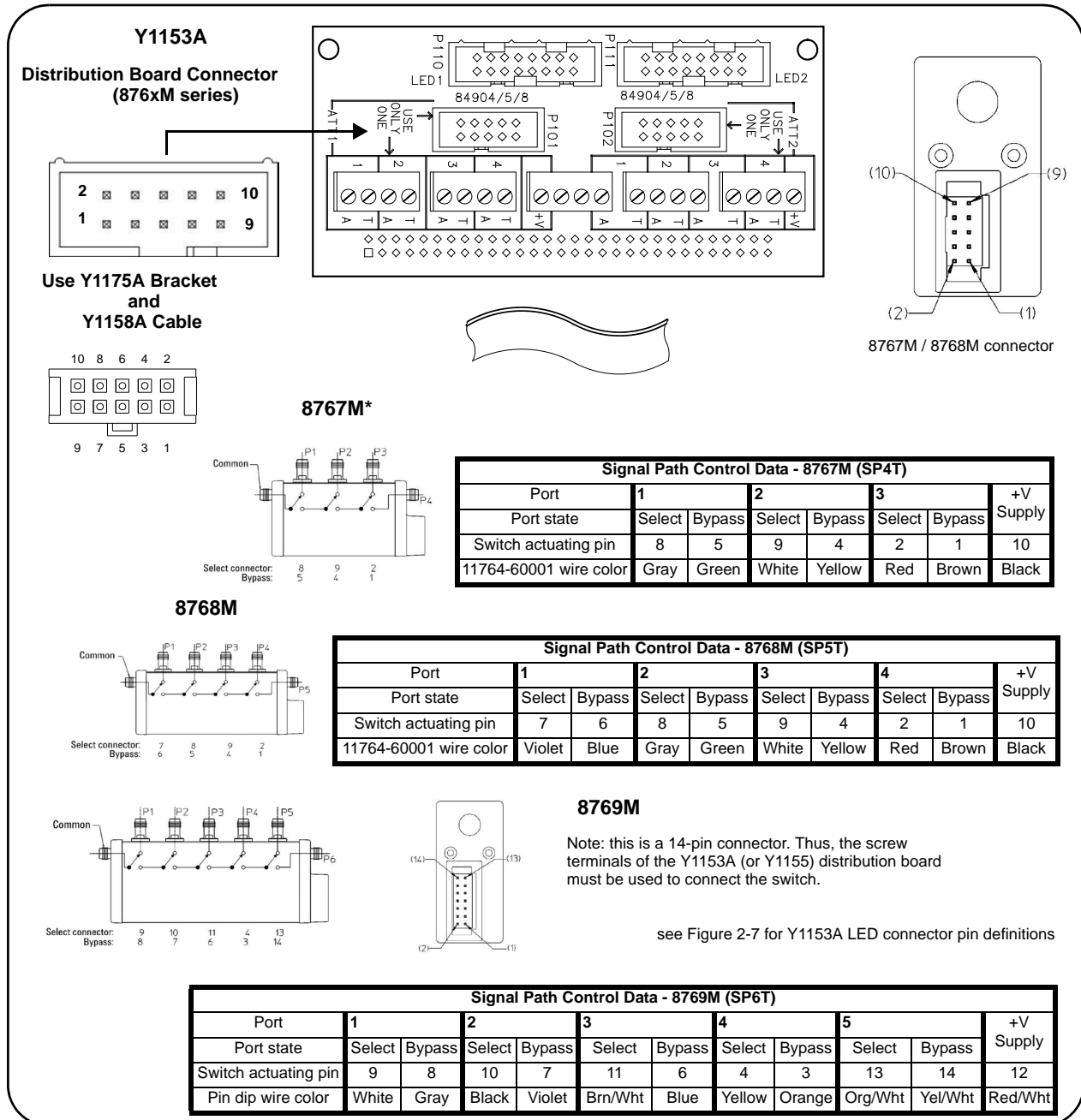

Figure 2-6. Agilent 8767/8/9M Port Definitions and Connections.

NOTE

The terminal information for the Agilent switches shown in Figure 2-6 was taken from the reference documents listed in Table 1-2. Refer to Table 1-2 for information on accessing these documents from the Agilent web-site.

Agilent 84904/6/7 K/L and 84904/5/8M Programmable Step Attenuators

Figure 2-7 identifies the pins of the 84904/6/7 K/L and 84904/5/8M step attenuators and their connections to the Y1153A distribution board.

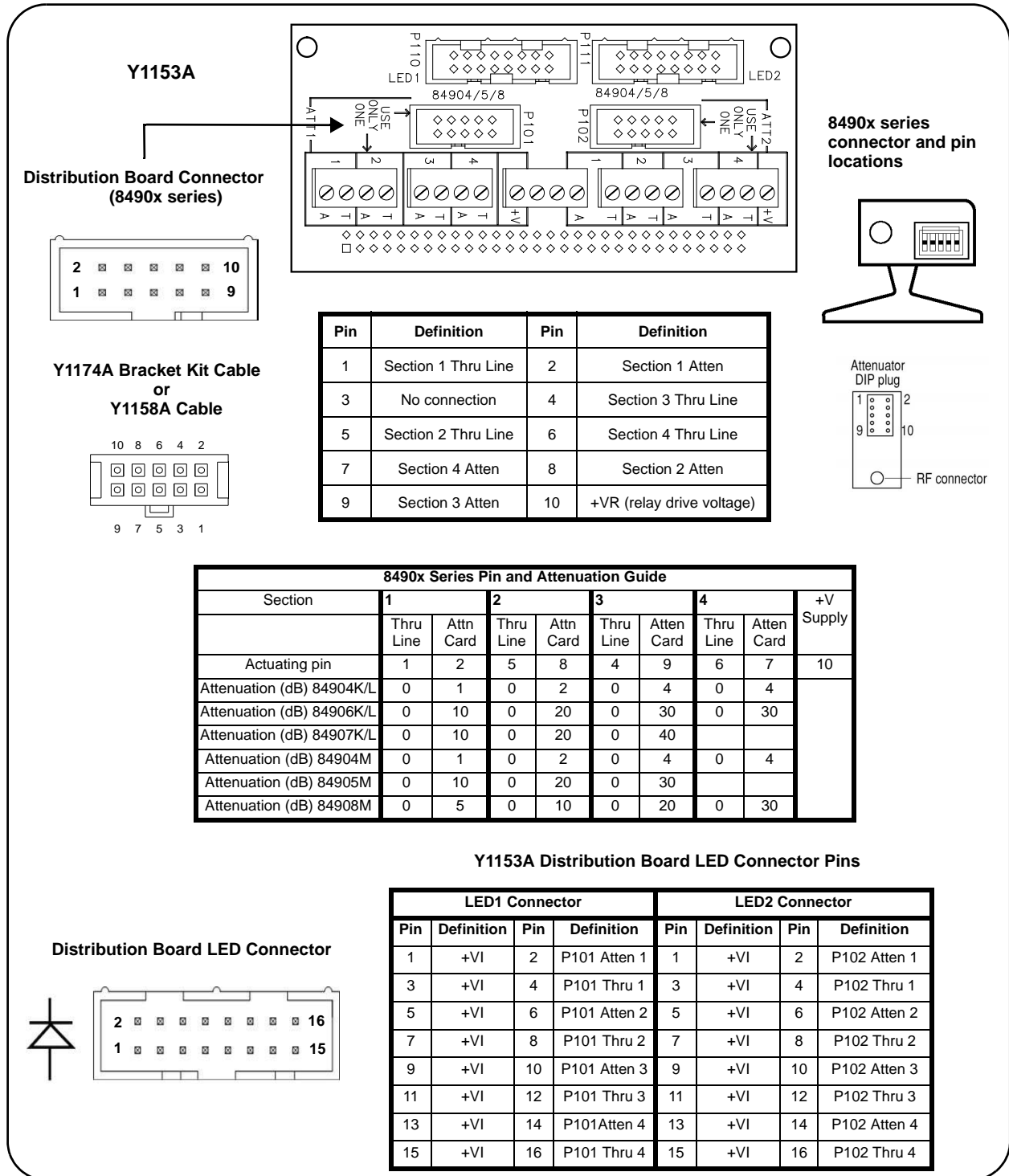

Figure 2-7. Agilent 84904/6/7 K/L Attenuator Pin Definitions and Connections.

NOTE

The terminal information for the Agilent switches shown in Figure 2-7 was taken from the reference documents listed in Table 1-2. Refer to Table 1-2 for information on accessing these documents from the Agilent web-site.

Agilent 8494/5/6/7 Programmable Step Attenuators

Figure 2-8 identifies the pins of the 8494/5/6/7 step attenuators and typical connections to the Y1153A distribution board.

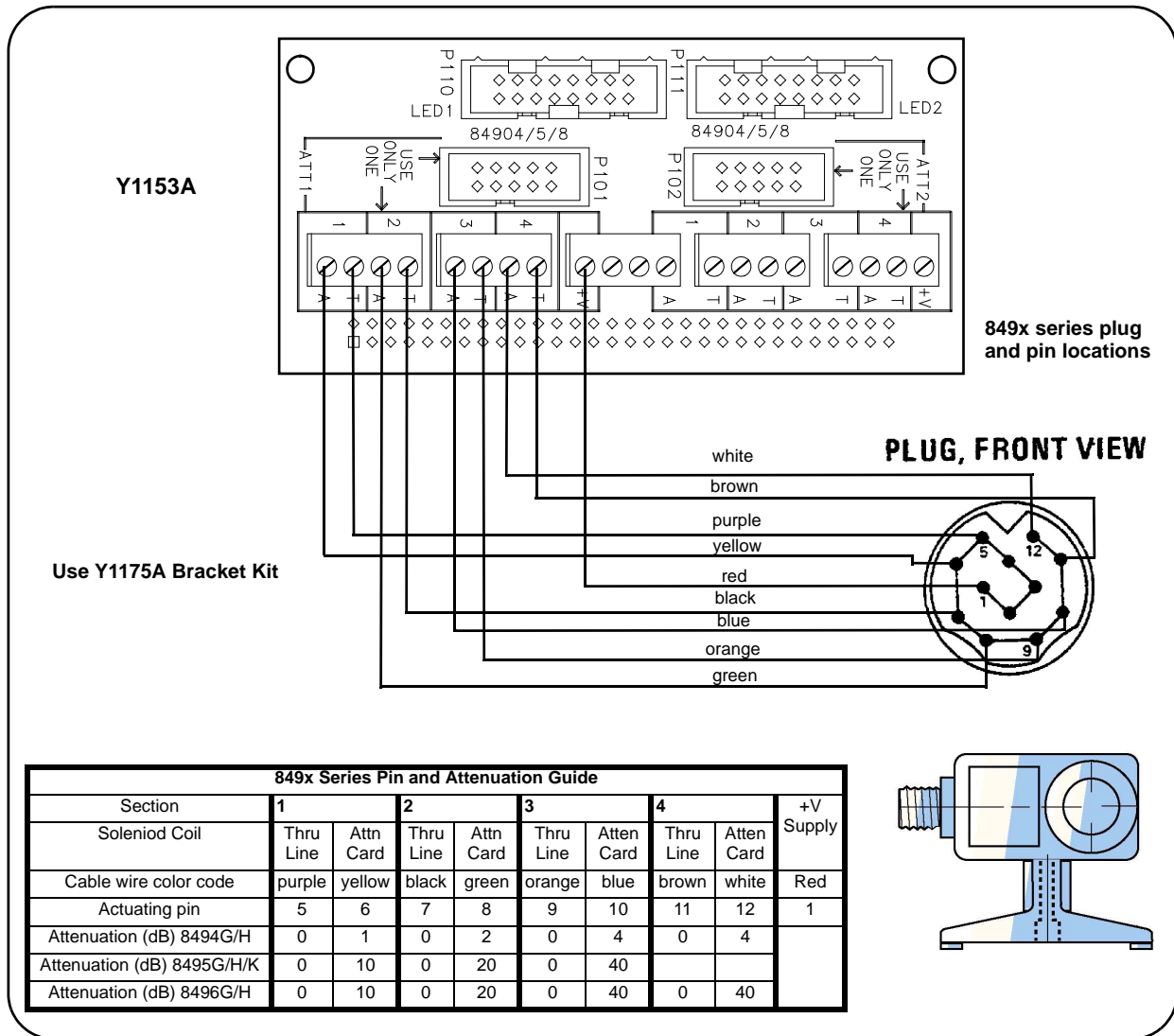

Figure 2-8. Agilent 8494 / 5 / 6 / 7 Attenuator Pin Definitions and Connections.

NOTE

The terminal information for the Agilent switches shown in Figure 2-8 was taken from the reference documents listed in Table 1-2. Refer to Table 1-2 for information on accessing these documents from the Agilent web site.

Agilent 849xG/H/K Programmable Step Attenuators Option 016

Figure 2-9 identifies the pins of the 8494/5/6/7 Option 016 Step Attenuators and typical connections to the Y1153A distribution board.

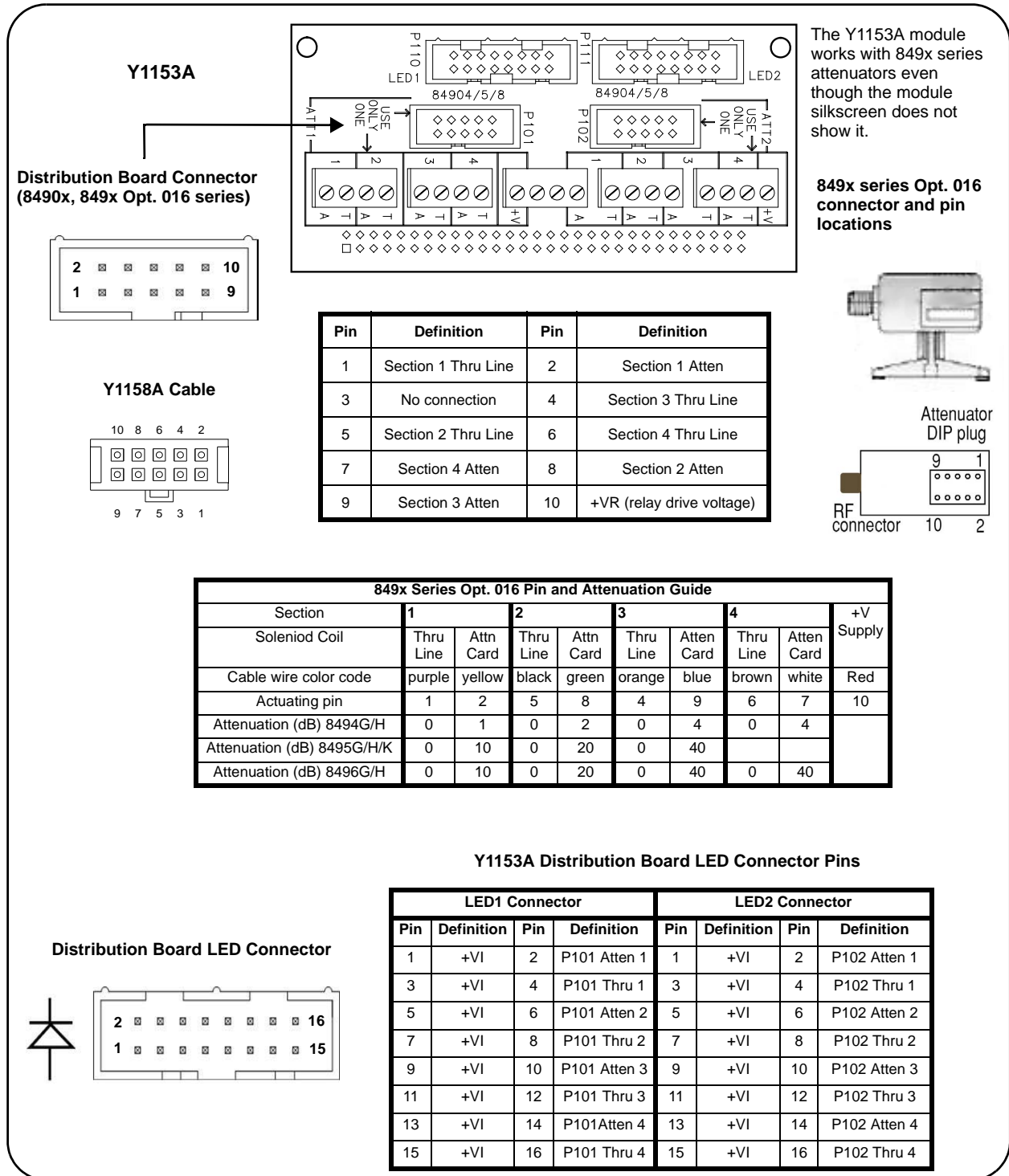

Figure 2-9. Agilent 8494 / 5 / 6 / 7 Attenuator Pin Definitions and Connections.

Agilent 87222 and L7222 Coaxial Switches

Figure 2-9 shows the pin definitions and orientation for the Y1154A distribution board and the Agilent 87222 and L7222 coaxial transfer switches.

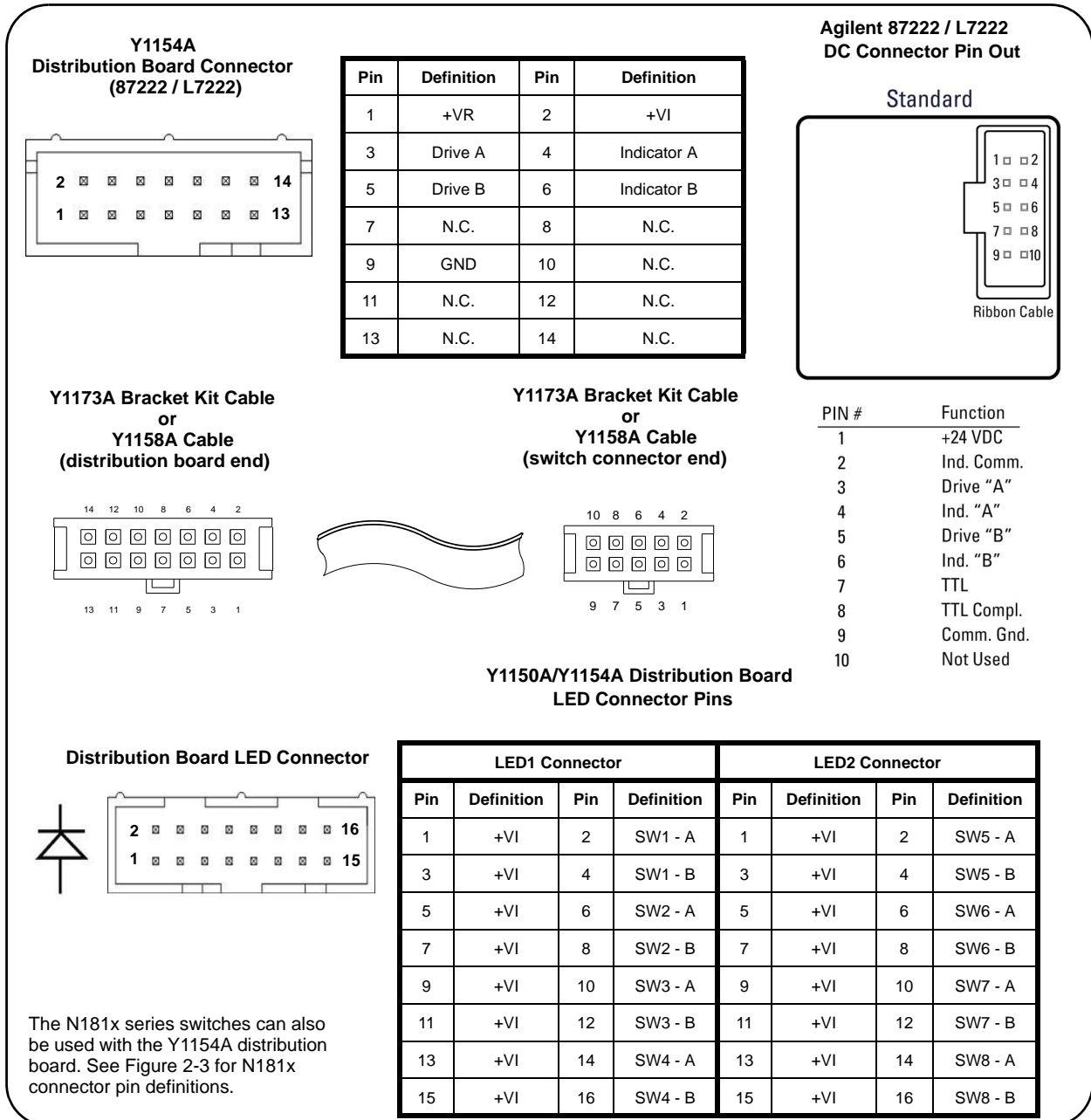

Figure 2-9. Agilent 87222 / L7222 Pin Definition and Orientation.

NOTE

The pin information for the Agilent switches shown in Figure 2-9 was taken from the reference documents listed in Table 1-2. Refer to Table 1-2 for information on accessing these documents from the Agilent web-site.

Agilent 8762 / 8763 / 8764 Series Coaxial Switches

Figure 2-10 identifies the 8762/8763/8764 switch terminals and typical connections to the Y1155A distribution board (w/ position indication).

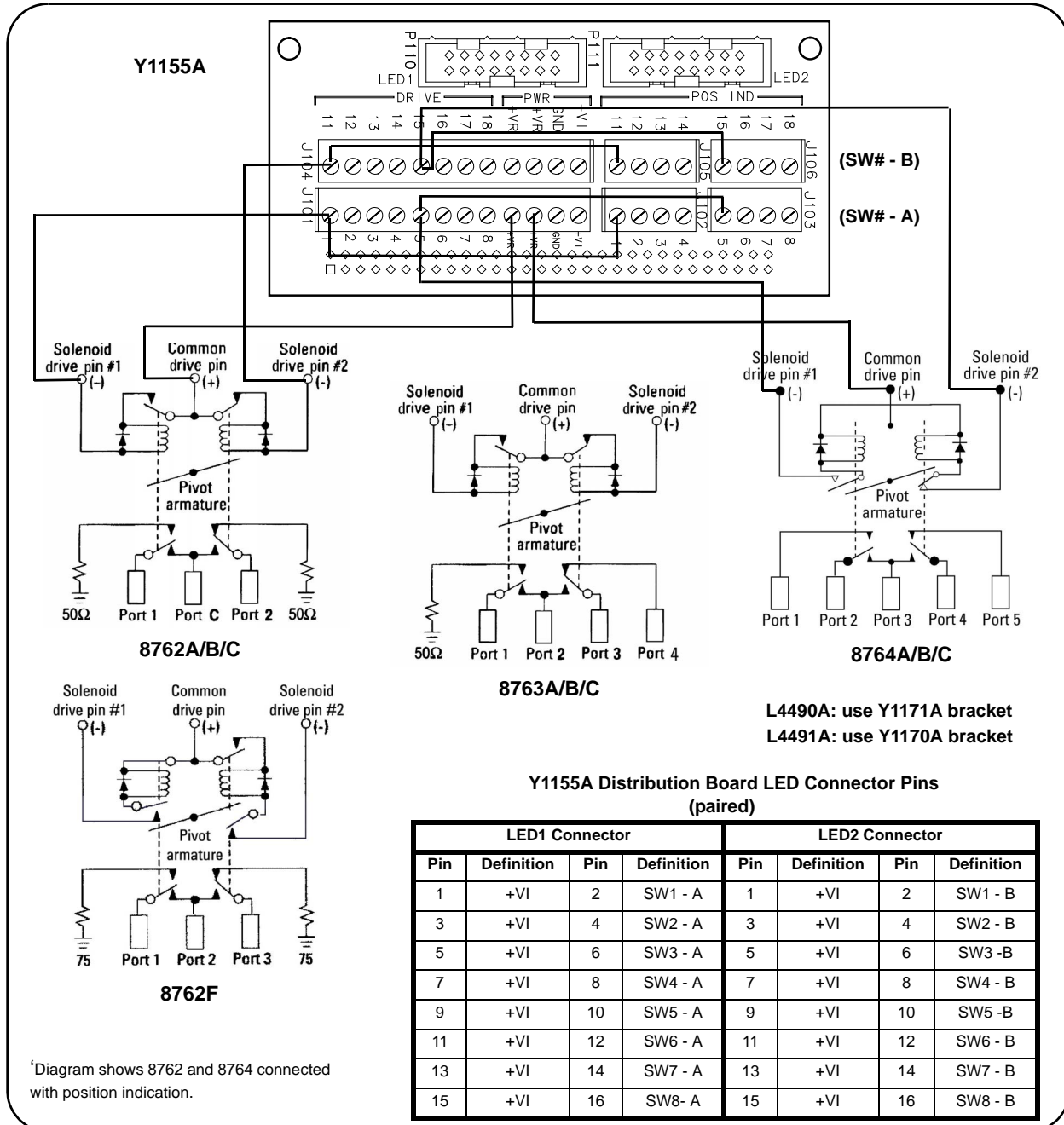

Figure 2-10. Agilent 8762 / 8763 / 8764 Terminal Connections.

NOTE

The terminal information for the Agilent switches shown in Figure 2-10 was taken from the reference documents listed in Table 1-2. Refer to Table 1-2 for information on accessing these documents from the Agilent web-site.

Agilent 8765 Series Coaxial Switches

Figure 2-11 identifies the terminals of the 8765 switches and typical connections to the Y1155A distribution board (with position indication).

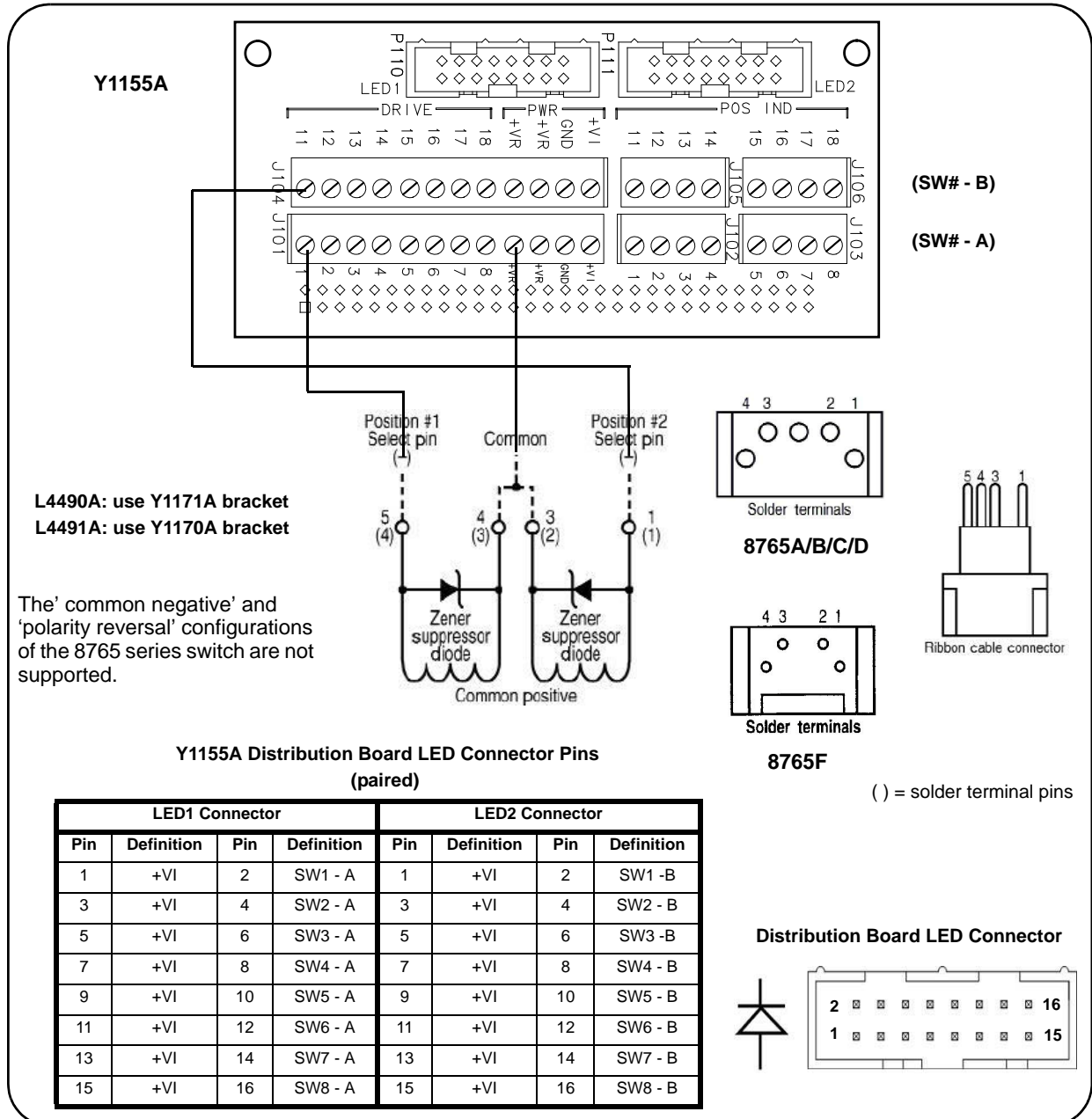

Figure 2-11. Agilent 8765 Terminal Connections.

NOTE

The terminal information for the Agilent switches shown in Figure 2-11 was taken from the reference documents listed in Table 1-2. Refer to Table 1-2 for information on accessing these documents from the Agilent web-site.

Agilent 8766/7/8/9K Microwave Single-Pole Multi-Throw Switches

Figure 2-12 identifies the terminals of the 8766/7/8/9K switches and typical connections to the Y1155A distribution board (* 8767K shown).

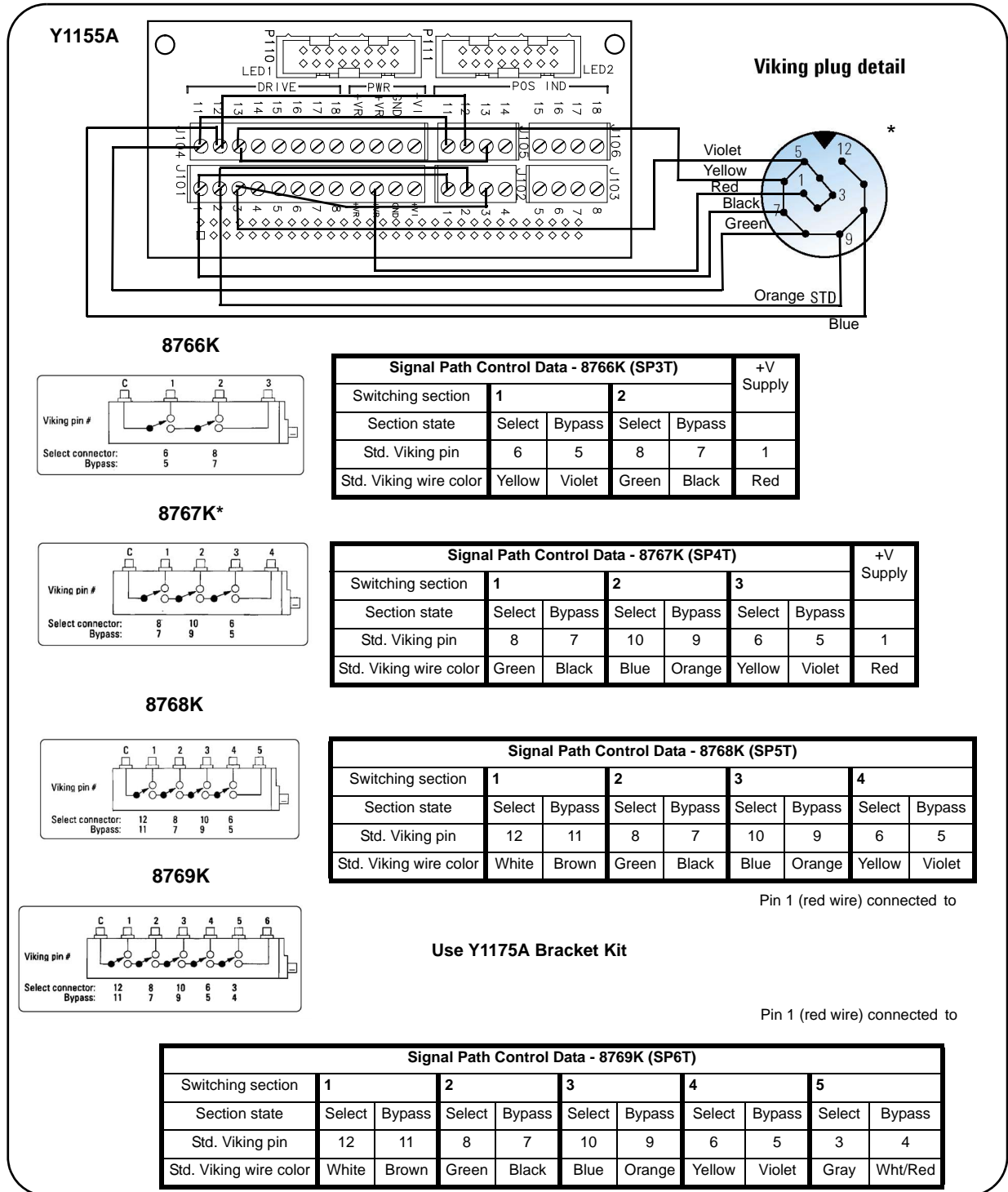

Figure 2-12. Agilent 8766/7/8/9K Section Definitions and Connections.

NOTE

The terminal information for the Agilent switches shown in Figure 2-12 was taken from the reference documents listed in Table 1-2. Refer to Table 1-2 for information on accessing these documents from the Agilent web-site.

Agilent U9397A / U9397C FET Solid State Switches

Figure 2-13 identifies the terminals of the U9397A/C switches and typical connections to the Y1155A distribution board (with position indication).

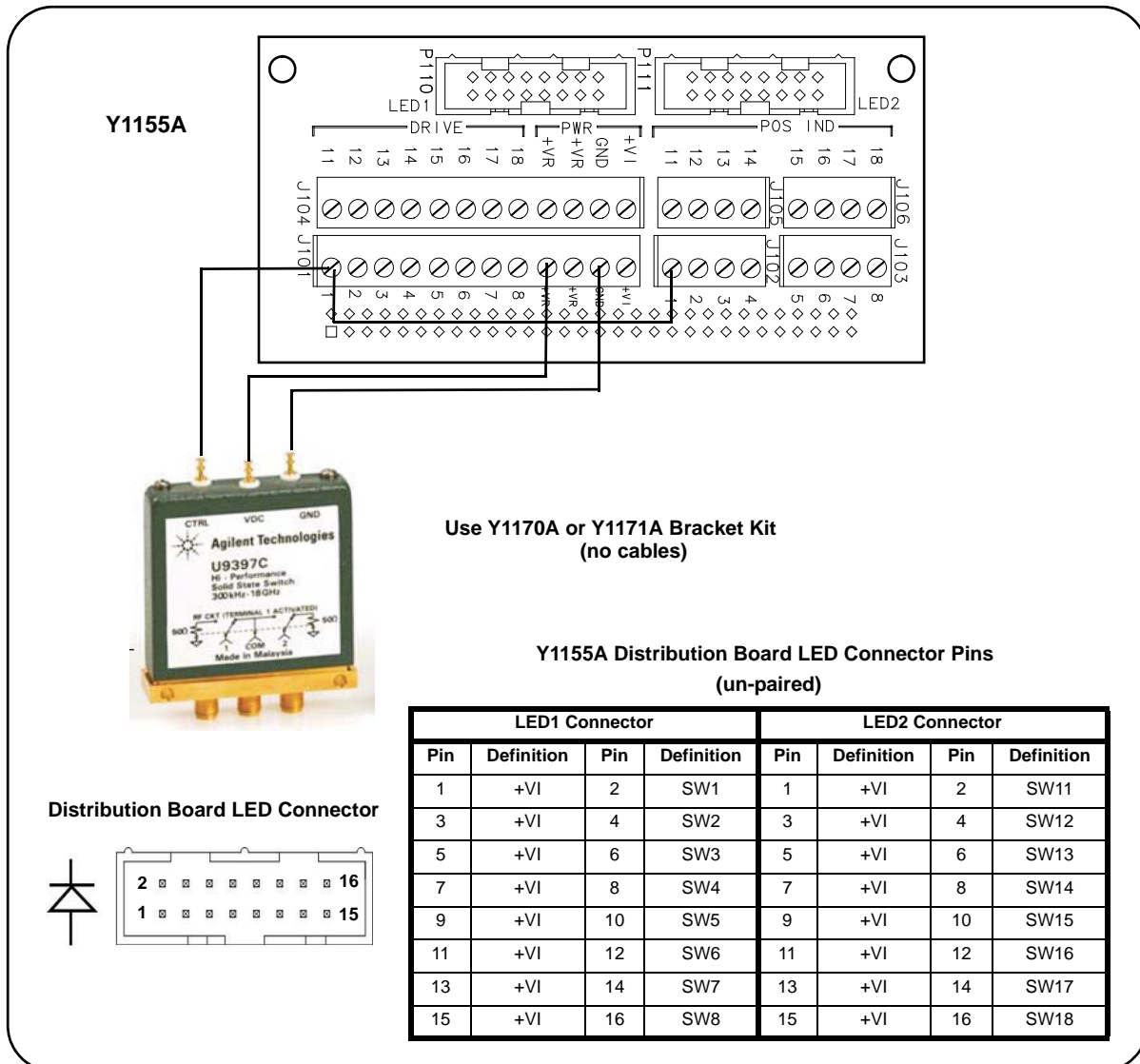
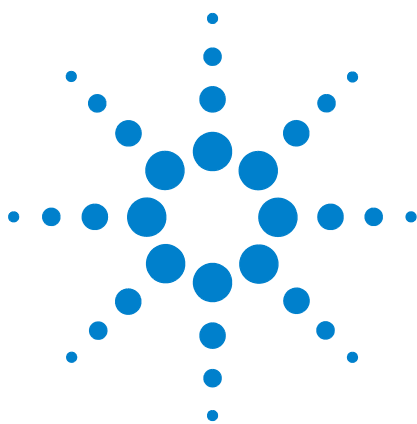

Figure 2-13. Agilent U9397A / U9397C Connector Definitions and Connections.

NOTE

The terminal information for the Agilent switches shown in Figure 2-13 was taken from the reference documents listed in Table 1-2. Refer to Table 1-2 for information on accessing these documents from the Agilent web-site.

2 Hardware Configuration



3 Software Installation and Configuration

Software Requirements	46
Installing the Agilent IO Libraries	47
Installing Instrument Drivers	48
Adding Instruments to the Interface	49
Configuring the LAN Interface	49
Configuring the GPIB Interface	53
Using Interactive IO	56
Applying Power	57
LAN Default Configuration	58
Firmware and Driver Updates	58
Downloading and Installing the Update Utility	58
Downloading the Firmware Update	59
Installing the Firmware Update	59
Updating the L4491A with Option 002	61
Downloading IVI-COM Driver and LabVIEW Driver Updates	63

This chapter contains information on IO libraries and drivers required to program the L4490A/L4491A from selected development environments. The chapter also provides information on configuring the instrument's LAN and GPIB interfaces and on updating the instrument firmware.

Refer to this chapter for specific information on:

- development environments and IO library/driver requirements
- installing the Agilent IO Libraries
- installing IVI (instrument) drivers
- LAN and GPIB configuration using Agilent Connection Expert
- updating the L4490A/L4491A firmware and IVI Drivers



Software Requirements

The manner and environments available to program the L4490A/L4491A are dependent upon the IO libraries and drivers installed. The IO software included with the L4490A/L4491A is contained on the following CDs:

- Agilent Automation-Ready CD: **Agilent IO Libraries Suite 15.0**
- Agilent L4490A/L4491A Product Reference CD-ROM:
 - **IVI-C, IVI-COM Drivers**
 - **National Instrument LabVIEW™**

Table 3-1 summarizes the environments, IO driver recommendations, and the location (media) where the specific drivers and libraries can be found.

Table 3-1. L4490A/L4491A Development Environments and Drivers.

Interface	Development Environment	IO Driver Recommendations
LAN	Web-enabled instrument interface > SCPI Command Interface window	Java™-enabled Web browser (available from www.java.com)
LAN, GPIB	Agilent Connection Expert > Interactive IO window	Agilent IO Libraries
LAN, GPIB	Microsoft® Visual Studio® 6.0 > Visual C++	VISA - Agilent IO Libraries CD or IVI-C - Product Reference CD
LAN, GPIB	Microsoft® Visual Studio® 6.0 > Visual Basic	VISA-COM - Agilent IO Libraries or IVI-COM - Product Reference CD
LAN, GPIB	Microsoft® Visual Studio® .NET > CSharp, C++, Visual Basic 7.0	VISA-COM - Agilent IO Libraries or IVI-COM - Product Reference CD
LAN, GPIB	Agilent VEE	IVI-COM - Product Reference CD
LAN, GPIB	National Instruments LabVIEW™	LabVIEW Plug&Play (with L44xx native mode driver) IVI-C - Product Reference CD
LAN, GPIB	National Instruments LabWindows/CVI	IVI-C - Product Reference CD

NOTE

Programming the L4490A/L4491A from the instrument's Web interface requires a Web-browser but no additional (i.e. user-installed) instrument drivers or libraries. The Web interface provides full access to RF switch platform functionality and its IO command log feature logs (SCPI) commands sent to the instrument via interface dialog boxes. The commands can then be copied and transferred to other development environments. Refer to Chapter 4 for more information on programming using the Web interface.

Installing the Agilent IO Libraries

The Agilent IO Libraries include the VISA and VISA-COM libraries used for programming the L4490A/L4491A in Microsoft® development environments (Table 3-1). The VISA and VISA-COM libraries allow you to send commands from the L4490A/L4491A SCPI command set to the instrument (see “L4490A/L4491A Programmers Reference Help” on the Product Reference CD-ROM). The IO libraries also include the ‘Configuration Expert’ utility described later in this chapter.

NOTE

The Agilent IO Libraries must be installed prior to installing drivers (e.g. IVI-C, IVI-COM) from the L4490A/L4491A Product Reference CD or from any other source.

The IO Libraries are contained on the Agilent Automation-Ready CD or may be downloaded from the Agilent website at:

<http://www.agilent.com/find/iosuite>

Before installing the IO libraries, review Table 3-2 to verify that your computer meets the specifications required for the software.

Table 3-2. Agilent IO Libraries Suite System Requirements.

Processor	450 MHz Intel Pentium® II or higher
Operating System	Windows XP Professional or Home Edition (Service Pack 1 or later) Windows 2000 Professional (Service Pack 4 or later)
Web Browser	Microsoft Internet Explorer 5.01 or greater (recommended)
Available Memory	128 MB (256 MB or greater recommended)
Available Disk Space	225 MB required for installation: - 160 MB for Microsoft .NET Framework - 65 MB for Agilent IO Libraries Suite 175 MB required for operation: - 110 MB for Microsoft .NET Framework - 65 MB for Agilent IO Libraries Suite
Video	Super VGA (800x600) with 256 colors

Close all applications on your computer. Insert the Agilent Automation-Ready CD into the CD-ROM drive. Follow the instructions as prompted for a *typical* installation. **Accept all default directories specified.**

If the IO libraries installation does not start automatically, select **Start > Run** from the Windows **Start** menu and type <drive>:\autorun\auto.exe where <drive> is the designator of the CD-ROM drive.

NOTE

If another vendor's implementation of VISA (Virtual Instrument Software Architecture) is currently installed on your computer, continue installation of the Agilent IO Libraries by installing Agilent VISA in *side-by-side* mode. More information on *side-by-side* operation can be found in the "IO Libraries Suite Help" (available after installation is complete) under "Using Agilent's and Other Vendors' Products Together".

After the IO libraries have been successfully installed, you have the option of starting 'Connection Expert' or closing the installation wizard. If you choose to start Connection Expert, continue with the "Interface Configuration" section of this chapter. Otherwise, continue with instrument driver installation as described below.

Installing Instrument Drivers

Interchangeable Virtual Instrument (IVI) drivers are available for programming the L4490A/L4491A using Microsoft® development environments, Agilent VEE, or National Instruments® LabVIEW™ (see Table 3-1). Insert the Agilent L4490A/L4491A Product Reference CD-ROM into your computer. The installation program will open the window shown in Figure 3-1.

NOTE

Installing the Agilent IO Libraries also installs the Interchangeable Virtual Instrument (IVI) Shared Components. The IVI Shared Components are required before IVI drivers (e.g. IVI-COM, IVI-C) can be installed from the L4490A/L4491A Product Reference CD.

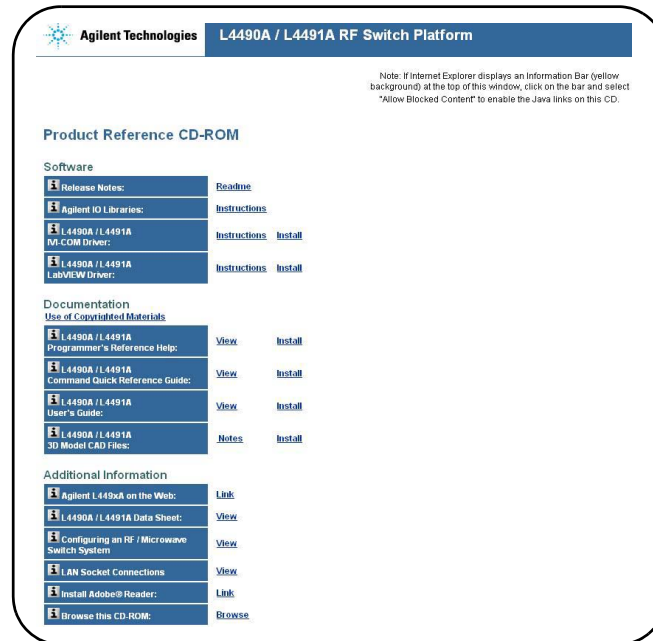

Figure 3-1. Product Reference CD-ROM Software (& Driver) Menu.

Install the appropriate driver based on the development environment you are using. **Accept all default directories specified during installation if prompted. Setup type "Typical" is applicable for most users.** (As previously noted, installing the Agilent IO Libraries installs the IVI Shared Components.)

Adding Instruments to the Interface

This section contains information for configuring the L4490A/L4491A LAN and GPIB interfaces using the Agilent IO Libraries 'Connection Expert' utility.

Configuring the LAN Interface

With the L4490A/L4491A turned on and connected to the PC (Chapter 2: Figure 2-1), start the Connection Expert utility by clicking the 'IO (control)' icon and selecting "Agilent Connection Expert" from the pop up menu as shown in Figure 3-2.

NOTE

The procedure for using Agilent Connection Expert to locate and configure the L4490A/L4491A is independent of the type of network you are using (private or site) and the network devices present (switches or routers).

Figures of the following Agilent Connection Expert windows represent Agilent IO Libraries Suite 15.0.

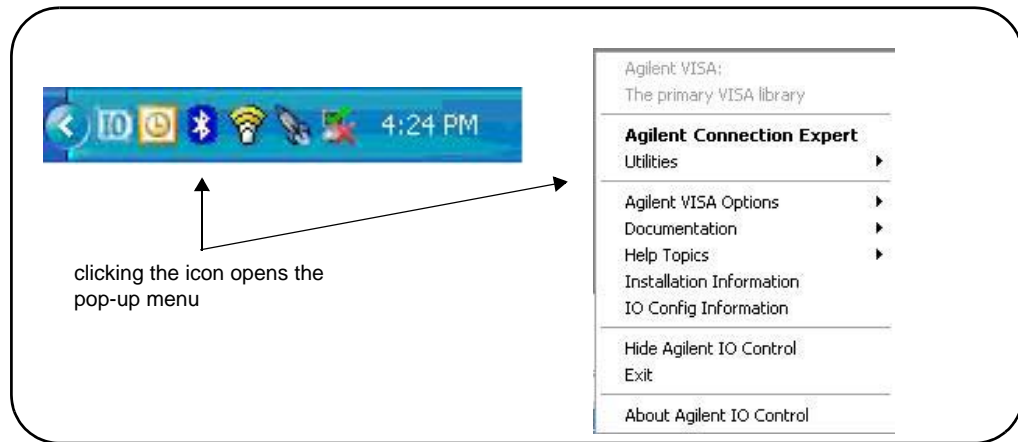

Figure 3-2. Starting Connection Expert.

Locating the Instruments

Agilent Connection Expert opens with a “welcome screen” and window similar to that shown in Figure 3-3. The computer interfaces available are configured during installation of the Agilent IO Libraries and are displayed in the left column (**Explorer** pane), the properties of the configured interface are displayed in the right column (**Properties** pane).

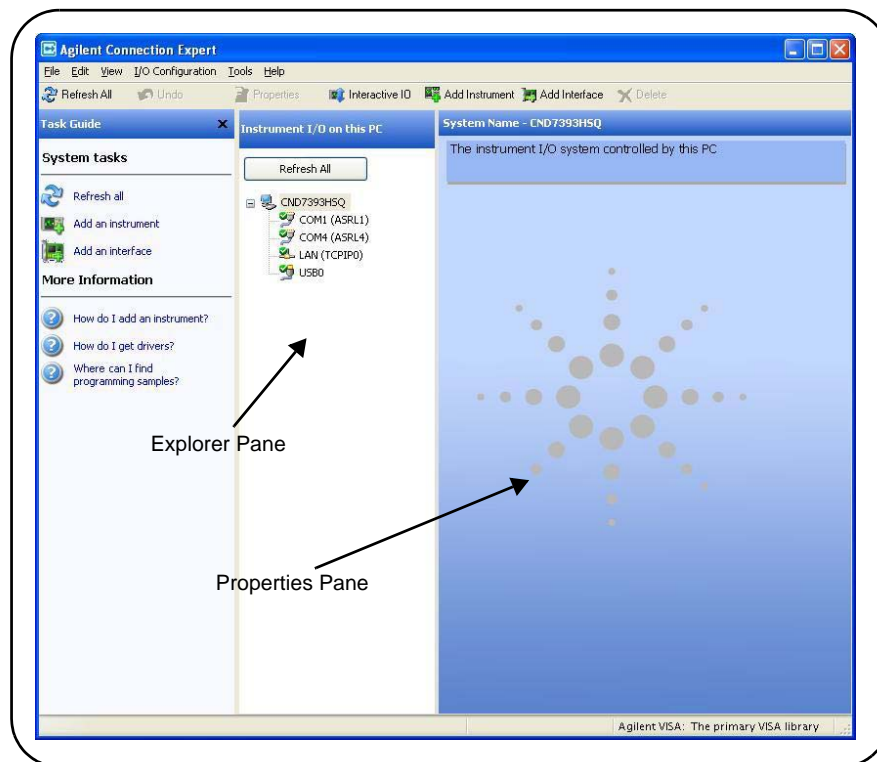

Figure 3-3. Agilent Connection Expert (ACE) Opening Window.

To search the network for instruments, click on “Add Instrument” located on the Connection Expert tool bar. From the “Add Instrument” window, select the LAN (TCPIP0) interface and click on ‘OK’. See Figure 3-4.

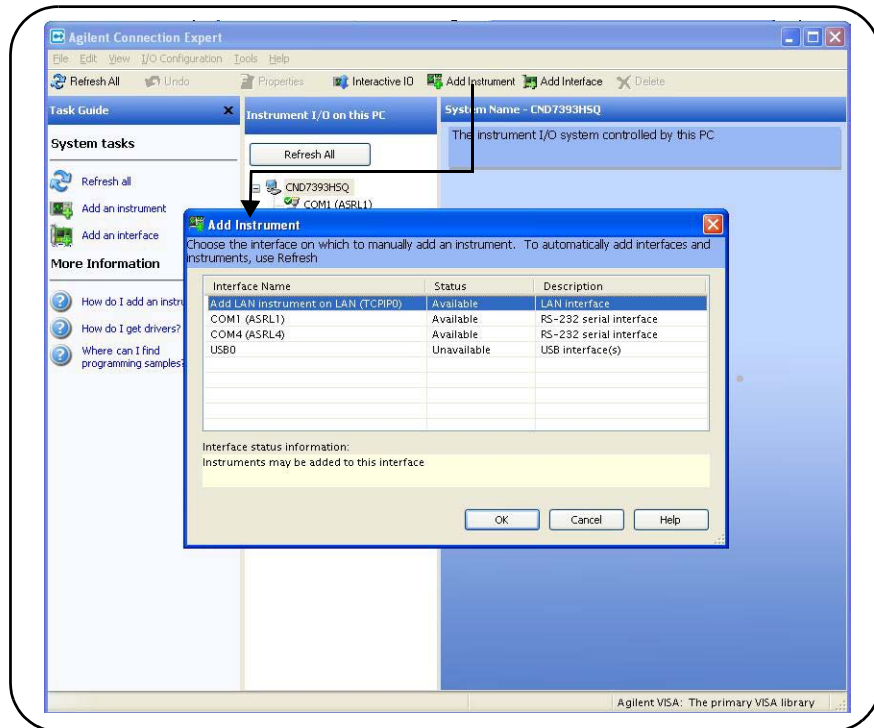

Figure 3-4. Agilent Connection Expert “Add Instrument” Window.

After clicking ‘OK’, Agilent Connection Expert (version 15) performs an automatic find (search) of all instruments on the same subnet as the computer. An example of instruments found on a subnet is shown in Figure 3-5.

The “Add LAN Instruments” window identifies the instrument’s IP address, MAC address, host name, and product number. In the example of Figure 3-5, the instrument is connected to the PC via a LAN switch with no DHCP server present. Thus, the host name is not registered and access to the instrument is through its IP address.

“Select” the desired instruments from the list and then click ‘OK’. Communication paths to the instruments are verified and the instruments are added to the configured interface. The instruments appear in the Agilent Connection Expert Explorer pane (Figure 3-3). Selecting the instrument in the Explorer pane displays its properties in the Properties pane.

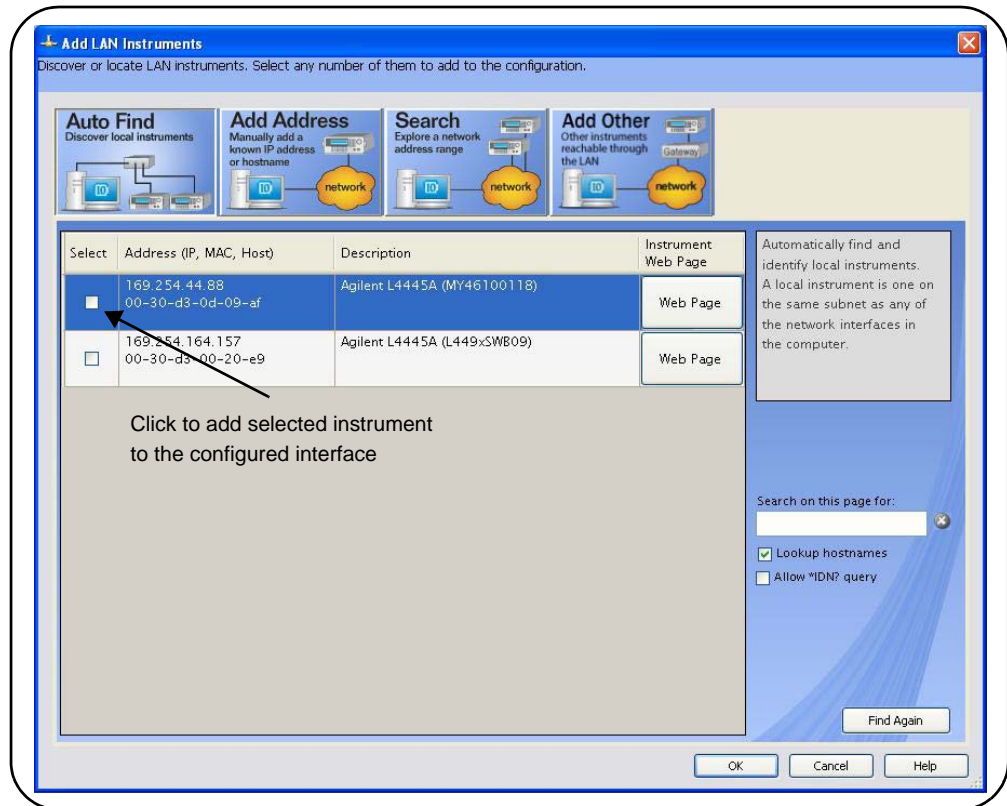

Figure 3-5. Instruments Found on a Local Subnet.

About IP Addresses and Host names

Dynamic Host Configuration Protocol (DHCP) and Automatic IP are enabled on the L4490A/L4491A when shipped from Agilent. This allows the instrument to automatically obtain an address on the network. If there is a DHCP server on the network, the server will assign the address to the instrument.

If there is not a DHCP server on the network, the L4490A/L4491A will automatically determine the address to use. The address will be in the range 169.254.1.1 to 169.254.255.255. If available, the instrument will try to acquire its default setting of 169.254.44.88.

Host Names The L4490A/L4491A has a default host name. The format of the host name is:

a-l449xa-yyyyy

where 'yyyyy' are the last five digits of the instrument's serial number. The instrument host name is reported by Agilent Connection Expert for network servers that support Dynamic Domain Name Service (DNS). For

network servers that do not support Dynamic DNS, only the IP address is reported.

Instrument Addressing During programming, the L4490A/L4491A is accessed through its address string which consists of an IP address:

```
TCPIP0::169.254.44.88::inst0::INSTR
```

or host name:

```
TCPIP0::A-L449XA-00118.agilent.com::inst0::INSTR
```

NOTE

A powerful tool for programming the L4490A/L4491A is the instrument's Web interface. The Web interface provides full access to L4490A/L4491A functionality and its IO command log feature logs (SCPI) commands sent to the instrument via interface dialog boxes. The commands can then be copied and transferred to other development environments. Chapter 4 contains detailed information on accessing and using the Web interface.

Configuring the GPIB Interface

NOTE

The following information assumes a GPIB interface card has been installed in your computer.

The L4490A/L4491A is an Agilent web-enabled instrument that offers a user interface which requires no user-installed IO drivers. Access to the instrument via the Web interface, however, is only available through the LAN connection.

Programming access to the L4490A/L4491A is also available through the instrument's optional GPIB interface. The GPIB connector is located on the rear panel of the instrument. Simultaneous LAN and GPIB connections to the instrument are allowed. The following information describes how instruments on the GPIB interface are configured using Agilent Connection Expert.

GPIB Connections

GPIB cables can be connected to the PC in a "star" (all cables connect directly to the computer) or "linear" (instrument to instrument) configuration.

Starting Agilent Connection Expert

Start Connection Expert by clicking the Agilent Control icon and selecting "Agilent Connection Expert" from the pop-up menu (Figure 3-2). If a GPIB card is installed in your computer, the (GPIB) interface was configured

during installation of the Agilent IO libraries and is displayed in the left column (**Explorer** pane) of the “welcome” screen (Figure 3-6).

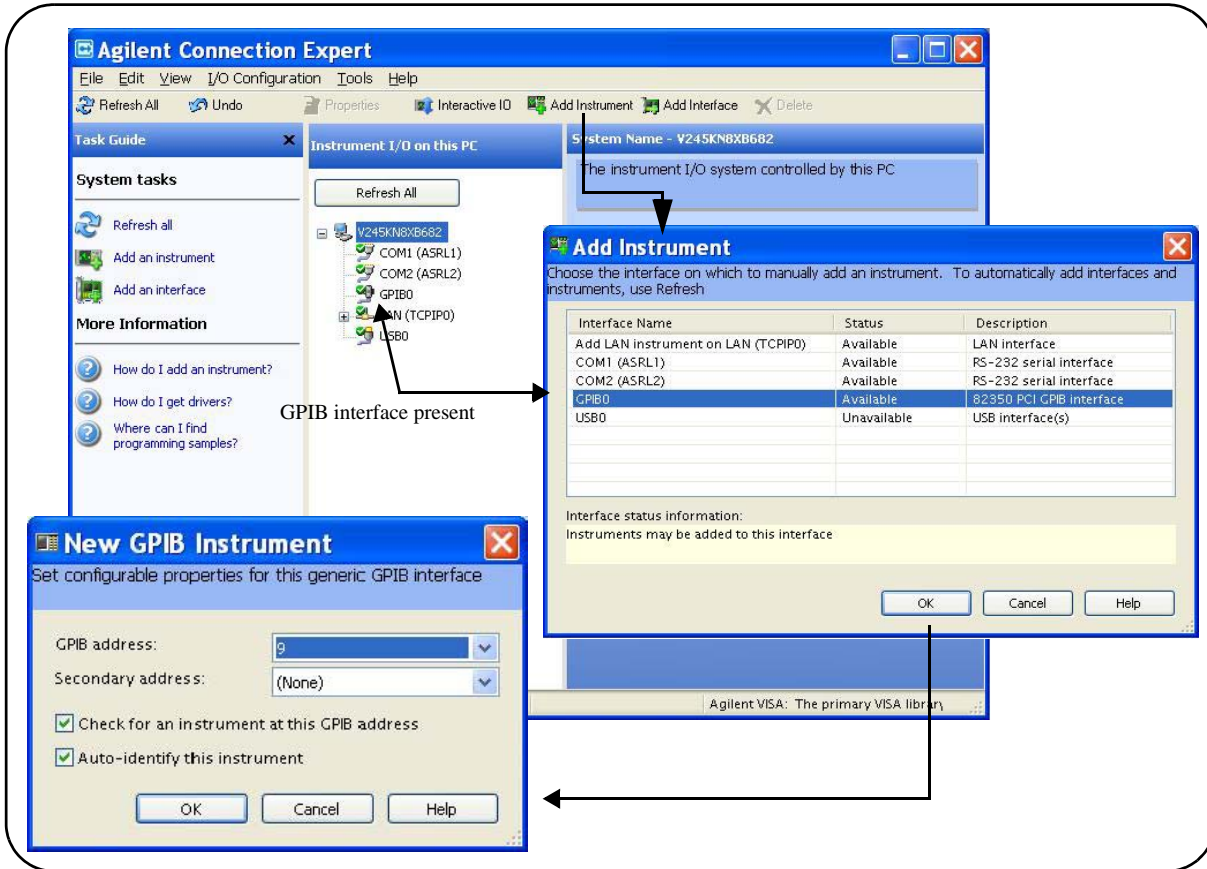

Figure 3-6. Adding Instruments to the GPIB Interface.

Adding Instruments to the GPIB Configuration

In the Connect Expert window, select “Add Instrument” on the tool bar. Select the GPIB interface in the “Add Instrument” window and click ‘OK’ (Figure 3-6).

In the ‘New GPIB Instrument’ window, select the L4490A/L4491A’s GPIB address (**note: factory-set address = 9**) and click ‘OK’.

Connection Expert will attempt to establish a communication path to the instrument. If the L4490A/L4491A is at the address specified, the instrument will be added to the list of GPIB-configured instruments.

NOTE

If the L4490A/L4491A GPIB address is unknown, the address can be queried from the LAN interface by sending the following command from the 'Interactive IO' or 'SCPI Command Interface' window:

SYSTEM:COMMunicate:GPIB:ADDRess?

See "Using Interactive IO" for more information.

The GPIB Address String

When programming the L4490A/L4491A over GPIB, the instrument's GPIB address is included in the address string as shown below:

GPIB0::9::INSTR

Changing the GPIB Address

The L4490A/L4491A GPIB address can only be changed programmatically. The command used to set the GPIB address is:

SYSTEM:COMMunicate:GPIB:ADDRess < address >

The command can be abbreviated by including only the upper-case letters in the command syntax. The command can be sent from the 'Interactive IO' window, or from the 'SCPI Command Interface' window - via a LAN connection.

When the address is changed, the new GPIB address IS NOT updated in Connection Expert if the instrument was previously configured.

From the Connection Expert window, highlight the instrument whose address was changed and then select 'Change Properties ...'. Within the configurable properties window, change the address to the new address setting and select 'OK' (Figure 3-6).

The Web-Enabled Instrument Interface and Interactive IO

The Web-enabled instrument interface featured in Chapter 4 is **not available** from the **GPIB** interface.

For GPIB operations, the Connection Expert 'Interactive IO' utility can be used to send SCPI commands from the L4490A/L4491A command set to the instrument. See the section "Using Interactive IO" for more information.

Using Interactive IO

The Connection Expert ‘Interactive IO’ utility provides another method (Table 3-1) of sending commands to the L4490A/L4491A. Similar to the ‘SCPI Command Interface’ window of the web-enabled interface, Interactive IO allows you to send any command in the L4490A/L4491A SCPI command set to the instrument. Interactive IO can be used to:

- troubleshoot communication problems
- issue a “device clear”
- learn the instrument's command set
- prototype commands and verify (instrument) responses before writing code

Interactive IO is available via the instrument’s GPIB interface. Figure 3-7 shows how Interactive IO is started from Connection Expert.

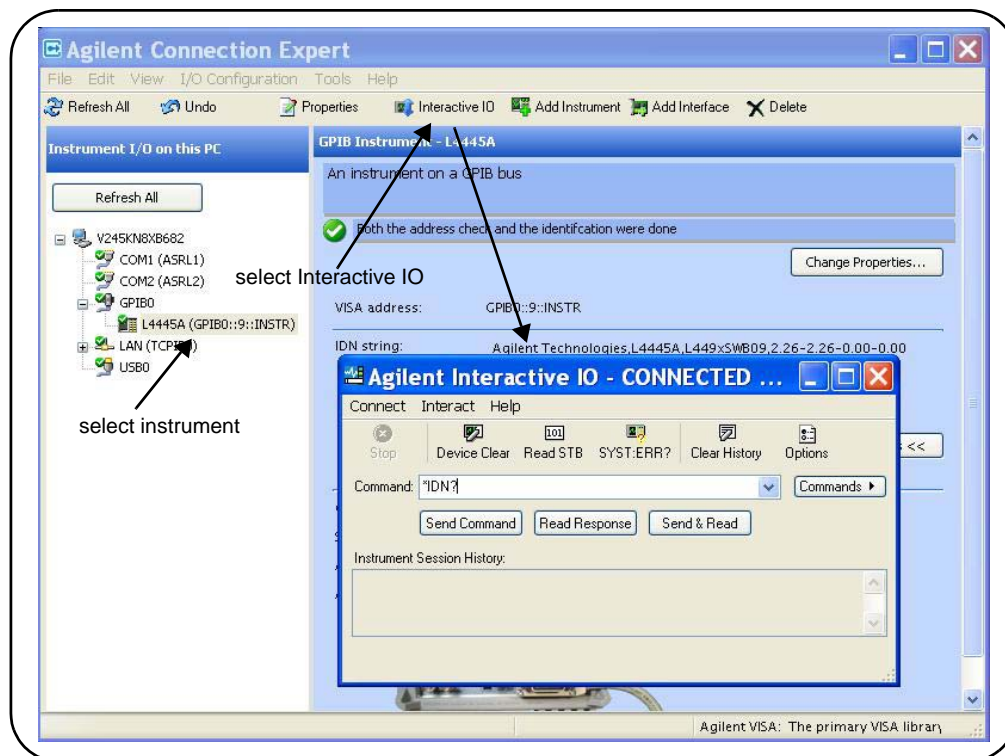

Figure 3-7. Selecting an Instrument and Starting Interactive IO.

NOTE

If the Interactive IO window is used to send the self-test (*TST?) command to the L4490A/L4491A, the “timeout” period may have to be increased to allow the results to be returned. This is done using the ‘Options’ link on the Interactive IO window.

Applying Power

When power is applied to the L4490A/L4491A, the instrument enters its power-on sequence which requires several seconds to complete. The front panel LEDs:

ATTN
LAN
PWR

provide information on the state of the instrument during power-on and during upgrades of the instrument firmware. Table 3-3 identifies the instrument states based on the color and functioning of the LEDs.

Table 3-3. L4490A / L4491A LED Definitions and Instrument States.

LED	Color	Instrument State
ATTN LAN PWR	Off Green Green	Instrument in "ready" state LAN connection established - instrument has an IP address Firmware download complete
ATTN LAN PWR	Off Off Off	Instrument is not turned on, and may or may not be connected to line power.
ATTN LAN PWR	flashing flashing Green	Power-on/boot-up. ATTN and LAN will flash red and then green during the power-on self-test.
ATTN LAN PWR	Off Red Green	No LAN connection due to: - disconnected LAN cable - failure to acquire an IP address - waiting for DHCP-assigned address
ATTN LAN PWR	Green (flashing) Green Green	Instrument Busy State - firmware download (LAN LED red if download over GPIB) - lengthy instrument operation in progress
ATTN LAN PWR	Red (flashing) Green Green	Instrument programming error or self-test error. Error queue is read using SYSTem:ERRor?
ATTN LAN PWR	Off Green (flashing) Green	Instrument identification. Activated from instrument Web interface: ON: <u>Turn on Front Panel Interface Indicator</u> OFF: <u>Turn off Front Panel Interface Indicator</u>

LAN Default Configuration

If necessary, pressing the recessed ‘LAN Reset’ button on the front or rear panel of the L4490A/L4491A will restore the instrument’s default LAN configuration. Table 3-4 lists the default LAN configuration settings.

Table 3-4. Default LAN Configuration Settings.

LAN Parameter	Default (Reset) Setting
DHCP	ON
Automatic IP Addressing	ON
IP Settings if DHCP Server Unavailable	IP Address: 169.254.44.88 (default) Subnet Mask: 255.255.0.0 Default Gateway: 0.0.0.0
DNS Server	0.0.0.0 (may be assigned by the DHCP server)
Host Name (registered with DDNS if available)	A-product number-last 5 digits of serial number
Net BIOS	ON
LAN Keep Alive	1800 (seconds)
Ethernet Connection Monitoring	ON - instrument monitors its LAN connection; will attempt to automatically reconnect if disconnected from network.
Password	None (disabled)

Firmware and Driver Updates

Firmware and driver updates (when available) for the L4490A/L4491A are available via the Web. This section contains information for locating and downloading the updates to your computer, and then installing the updates in the instrument.

Downloading and Installing the Update Utility

L4490A/L4491A firmware updates are installed in the instrument using the Agilent Firmware Update Utility. The utility and firmware update can be found on the Web at either:

www.agilent.com/find/L449xA
www.agilent.com/find/L4490A
www.agilent.com/find/L4491A

Once this page is displayed, highlight ‘Technical Support’ and from the Technical Support window select ‘**Drivers and Software**’. Within the drivers and software list, scroll to and select:

L449xA Firmware Update revision <revision number>

From this window, go to ‘Documents and Downloads’ and select:

Agilent L449xA Firmware Update Utility

When prompted, select ‘Run’ to install the utility. The default installation directory is C:\Program Files\Agilent\Firmware Update Utility. The utility will also be added to the ‘start’ menu under “Agilent”.

Downloading the Firmware Update

Return to the Web page and under “Documents & Downloads and select:

Agilent L449xA Firmware Revision <revision number>

When prompted, select ‘Run’ to extract and download the file to your PC. **Note the directory location as you will need to specify the path to the firmware file when you run the update utility.**

NOTE

Depending on the interface to the L4490A/L4491A, the firmware update utility will require the instrument’s LAN or GPIB address. Note this address before starting the utility.

Installing the Firmware Update

Updating the L4490A/L4491A firmware involves updating firmware in the instrument controller box and in the 34945EXT module. For L4491A instruments with Option 002 - a second 34945EXT module, the update procedure must be repeated for that module.

1. From the installation directory or ‘start’ menu, start the utility and select ‘Next’ until the window shown in Figure 3-8 appears.
2. Using the ‘Browse’ button, specify the path to the firmware file. Once specified, the instrument model number will appear in the ‘Applicable Model’ window along with the revision and instrument description. Select ‘Next’.

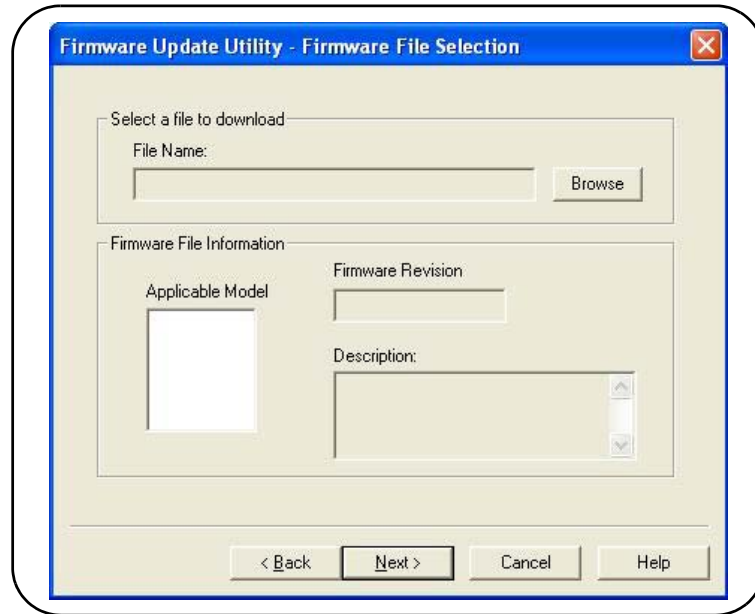

Figure 3-8. Firmware Update Utility File Selection Window.

NOTE

The 'Applicable Model' window lists the instruments which may be updated by the specified firmware (.xs) image. The window is not used to select the instrument receiving the firmware update.

3. Select the I/O interface between the PC and the instrument and then select 'Next'. Enter the machine name/IP address or GPIB address as prompted (Figure 3-9). Select 'Update' to start the update process.

4. The update process takes several minutes to complete. The front panel 'ATTN' LED (Table 3-3) will flash green during this time. DO NOT cycle power on the instrument during the process.

When there is no longer instrument activity as indicated by the front panel LEDs (Table 3-3), cycle power on the instrument.

To verify that the L4490A/L4491A controller box and the 34945EXT have the same firmware revision, the following commands can be sent from the Interactive IO utility within Agilent Configuration Expert:

```
SYST:CTYPE? 1      !returns firmware revision of the controller box
```

```
SYST:CTYPE:RMOD? (@1100) !returns firmware revision of the 34945EXT
```

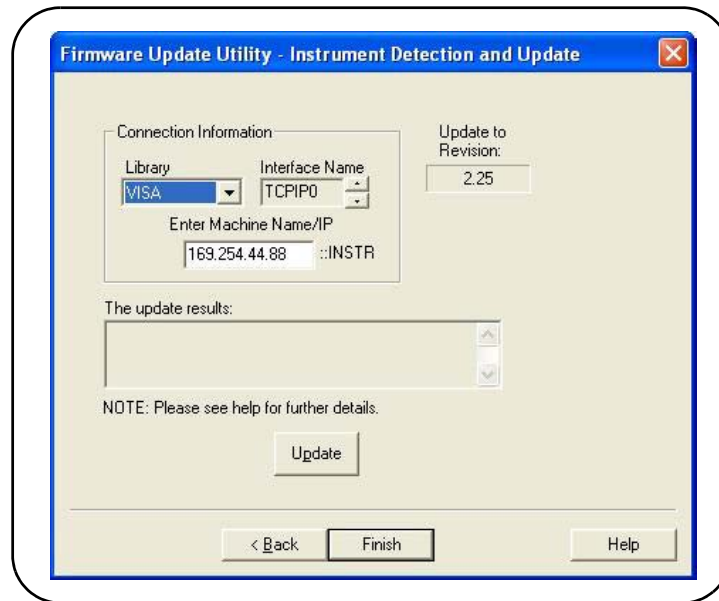



Figure 3-9. Specifying the Instrument Address.

NOTE

Following a firmware update, Agilent Connection Expert may report that the L4490A/L4491A configuration has changed. This is represented by a yellow triangle and an exclamation point (!) next to the updated instrument. Select the instrument name, select 'Change Properties', and then select either 'Test Connection' or 'Identify Instrument' to update Connection Expert.

Updating the L4491A with Option 002

For L4491As with Option 002 - a second 34945EXT module, steps 1-4 of the firmware update procedure must be repeated with the L4491A controller box connected via ribbon cable to the "Control Bus" port of the second 34945EXT. Steps 5-7 describe how to access the cable and move it to the second 34945EXT.

5. Turn off the L4491A and disconnect the power cord. Remove the top and bottom covers of the L4491A as shown in Figure 1-1.
6. Facing the back of the instrument, locate the ribbon cable leading from the controller box to the "Control Bus" port of the master (right side) 34945EXT. Remove the two screws connecting the ribbon cable to the port (Figure 3-10).

7. Remove the ribbon cable from the plastic clamps, then route the cable to the second (left side) 34945EXT and connect it to the Control Bus port. Note that the port terminals are inverted relative to the terminals of the right 34945EXT. Insure the ribbon cable is securely connected to the left side 34945EXT port. It is not necessary to insert the screws.

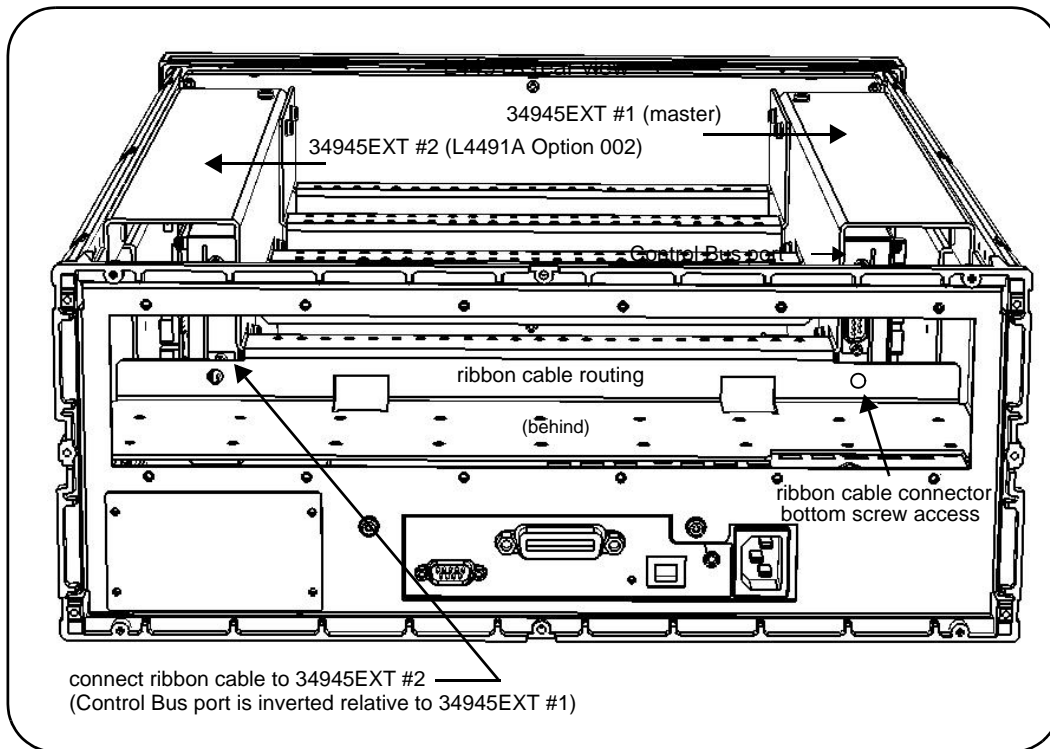

Figure 3-10. Removing the Ribbon Cable from the “Master” 34945EXT.

8. Place the L4491A in a stable position and reconnect the power cord and LAN cable (if removed). Turn on the L4491A.



CAUTION

Use care when handling the L4491A chassis with the top and bottom covers removed as components within the chassis are susceptible to damage from ESD.

9. Repeat steps 1-4 to update the firmware on the second 34945EXT. Once the update completes (step 4), turn off the L4491A and disconnect the power cord.

Remove the ribbon cable from the second 34945EXT and reconnect it to the master (right side) 34945EXT. Re-insert the excess cable in the clamps and re-insert and tighten the cable connector screws.

10. Re-install the top and bottom covers, connect the power cord, and turn on the instrument.

To verify that the second 34945EXT has the same firmware revision as the controller box and the master 34945EXT, the following command can be sent from the Interactive IO utility within Agilent Configuration Expert:

```
SYST:CTYPE:RMOD? (@1200) !returns firmware revision of 2nd 34945EXT
```

NOTE

For L4490A and L4491A systems with 34945EXT modules external to the chassis, the firmware update procedure must be repeated for **each** 34945EXT. Connect the external 34945EXT (one at a time) directly to the L4490A or L4491A controller box with the ribbon cable that is used to connect to the master 34945EXT (see Figure 2-1).

Downloading IVI-COM Driver and LabVIEW Driver Updates

IVI-COM and LabVIEW drivers for the L4490A/L4491A are provided on the Product Reference CD-ROM that ships with the product. Updates to these drivers can be found on the Web at either:

www.agilent.com/find/L449xA

www.agilent.com/find/L4490A

www.agilent.com/find/L4491A

Once this page is displayed, highlight 'Technical Support' and from the Technical Support window select '**Drivers and Software**'. The drivers and associated 'readme' files are located within this list.

3 Software Installation and Configuration

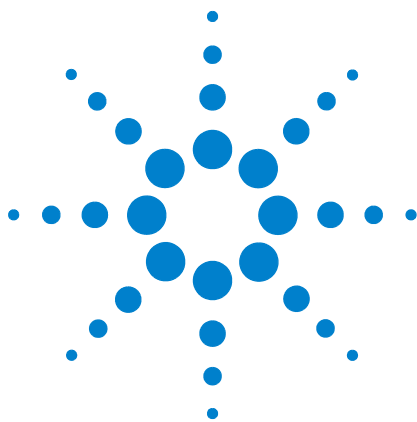

4 Introduction to Programming

Getting Started with the L4490A/L4491A Web-Enabled Interface	66
Connecting to the Instrument and Viewing its Home Page	67
An Overview of the 'Browser Web Control' Page	67
SCPI Command Interface	72
Logging SCPI Commands	73
System Verification	75
Switch and Attenuator Programming	80
Agilent N1810/N1811/N1812 Series Switches	80
Agilent 87104/87106/87406 - L7104/L7106/L7204/L7206 Switches	82
Agilent 87204 / 87206 Series and 87606 Switches	84
Agilent 8490x Series / 849x Series Attenuators and 876xM Series Switches	86
Agilent 87222 Series and L7222C Switches	88
Agilent 876x Series and U9397A/C Switches	90
Sequence Programming	92
Using L4490A/L4491A Digital IO and Relay Driver Option 004	93
Connector Pin Definitions	93
Configuring the Digital IO and Relay Drive Lines	96
Restoring L4490A/L4491A Factory Settings	97

This chapter contains information on using the L4490A/L4491A built-in Web interface for switch and attenuator control.

Refer to this chapter for specific information on:

- opening the instrument's Web interface
- the instrument's home Web page
- logging SCPI commands for transfer to other programming environments
- L4490A/L4491A signal path verification
- using the Web interface to configure the 34945EXT and distribution boards, and to control channels
- using programming sequences
- using L4490A/L4491A Option 004
- power-on and reset settings



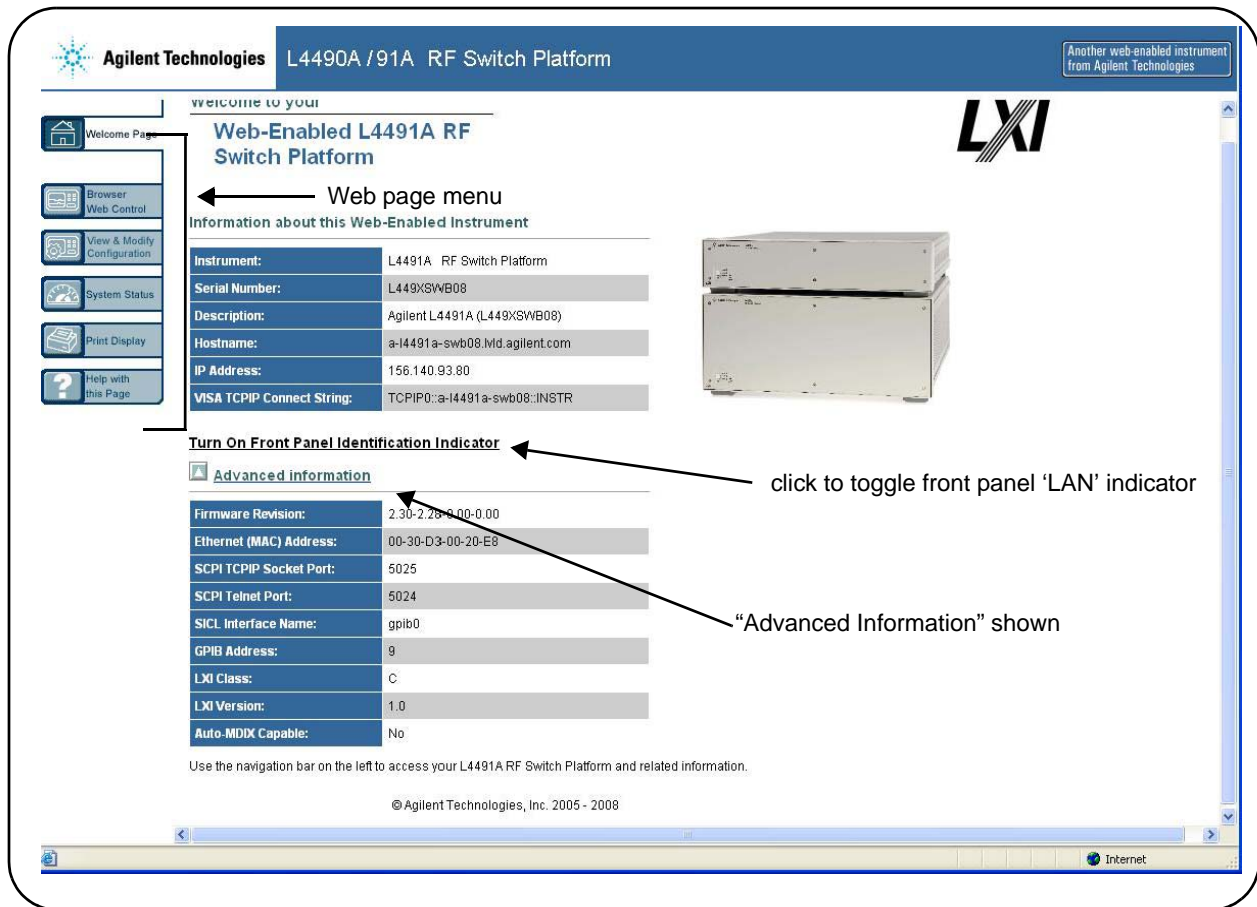

Figure 4-1. The L4490A/L4491A Programming Home Page.

Getting Started with the L4490A/L4491A Web-Enabled Interface

By far, the easiest way to begin programming the L4490A/L4491A RF Switch Platform is through the instrument's built-in Web server. As mentioned in Chapter 3 (Table 3-1), the Web server's instrument interface requires a Java™-enabled Web browser, but no additional user-installed drivers or libraries. Full access to the instrument's functionality is available through the interface.

NOTE

This section describes the Web pages and windows primarily used to program the 34945EXT module within the RF switch platform. Refer to "Help with this Page" associated with each Web page for additional information on functions or pages not covered in this manual.

Connecting to the Instrument and Viewing its Home Page

With the RF switch platform and 34945EXT(s) connected as shown in Figure 2-1, connect the switch platform to the PC using one of the options shown. Note that a LAN cross-over cable is only required for a direct connection between the instrument and the PC, and only if the PC does not have Auto-MDIX (Gigabit Ethernet).

Obtaining the Host Name or IP Address

In order to connect a Web browser to the instrument, the L4490A/L4491A host name or IP address is required. The host name set at the factory has the format:

a-l449xa-yyyyy

where 'yyyyy' are the last five digits of the instrument's serial number. The serial number of the L4490A/L4491A is located on the back of the instrument.

The L4490A/L4491A IP address can be determined using 'Agilent Connection Expert' as described in the section "Adding Instruments to the Interface" in Chapter 3.

Start the computer's web browser and enter the host name or IP address in the browser's address window. The L4490A/L4491A home page should appear as shown in Figure 4-1.

The instrument home page displays IO information, can be used to identify a connected instrument, and contains the menu tabs for accessing other Web pages and additional instrument functionality.

An Overview of the 'Browser Web Control' Page

Configuration of the 34945EXT, distribution boards, and switch/attenuator channels occurs through the 'Browser Web Control' page. Clicking the 'Browser Web Control' tab on the home page opens the page shown in Figure 4-2.

4 Introduction to Programming

The figure displays the Agilent Technologies L4490A/91A RF Switch Platform web interface. The main interface includes a navigation menu on the left with options like 'Welcome Page', 'Browser Web Control', 'View & Model Configuration', 'System Status', 'Print Display', and 'Help with this Page'. The main content area shows 'Select Module' with options '(1) uW Switch Driver' and '(2) Digital IO and Relay Driver'. Below this is the 'Microwave Switch/Attenuator Driver' section, which includes 'Remote Module 1 Settings' and a 'Channel Drives are OFF' status. A 'bank diagram' is shown as a grid of channels (Ch 1101 to Ch 1118) with 'Open' and 'Close' buttons and 'IsOpen' indicators. A 'Distribution Board' is identified as 'Agilent Y1150A'. Several configuration windows are overlaid: 'System Overview' (top left) showing logs and instrument state; 'SCPI Command Interface' (top right) for entering commands like 'SYST:RMOD:RES 1'; 'Remote Module 1 Configuration' (middle right) for setting channel drive and operations; 'Bank 1 Configuration' (bottom left) for LED drives and channel drive type; and 'Channel 1108 Configuration Information' (bottom right) for detailed channel settings like actuation type and pulse width. Arrows indicate the flow of configuration from the main interface to these specific windows.

Figure 4-2. 34945EXT, Distribution Board, and Channel Configuration.

Observe Only / Allow Full Control

These settings disable/enable control of the 34945EXT from the Web interface. When 'Observe Only' is set, many of the features programmable from the dialog boxes (Configure Bank 1..., Configure Module..., etc.) are disabled.

Viewing Remote Modules

The remote module is the 34945EXT module within the L4490A/L4491A (Figure 2-1). L4491A Option 002 adds a second 34945EXT to the L4491A platform. The L4490A/L4491A can support up to eight 34945EXT modules external to the switch platform. The remote module currently selected is the one configured by the interface.

Remote Module (34945EXT) Configuration Window

The remote module (34945EXT) configuration window provides settings that apply to **all** banks (i.e. distribution boards) on the EXT module.

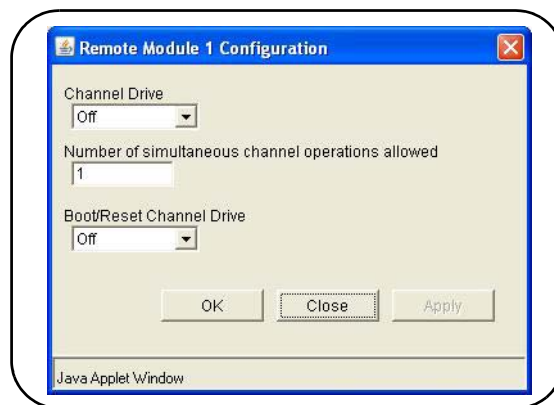

Figure 4-3. The Remote Module Configuration Window.

These settings include:

- channel drive source** - this is the source of the power supply for the EXT module. For the master 34945EXT, valid sources are off, internal, and external. For all slave 34945EXTs, valid sources are off and external.
 Note that the channel drive source must be off prior to configuring individual switches or attenuators (see "Switch/Attenuator Channel Configuration Window").
- number of simultaneous operations** - this sets the number of simultaneous channel activations (open/close) per command. For example, given a list of four channels and a specified number of four operations, a single open or close command will attempt to open/close all four channels simultaneously.

This feature is limited to external channel drive sources (power supplies) with the capability to drive multiple channels.

- **boot/reset channel drive** - this parameter specifies the channel drive source setting following a re-boot (power-up) or reset of the instrument.

Switch/Attenuator Channel Configuration Window

The switch/attenuator channel configuration window is opened by right-clicking near the 'IsOpen' or 'IsClosed' labels on the 'programming diagram'.

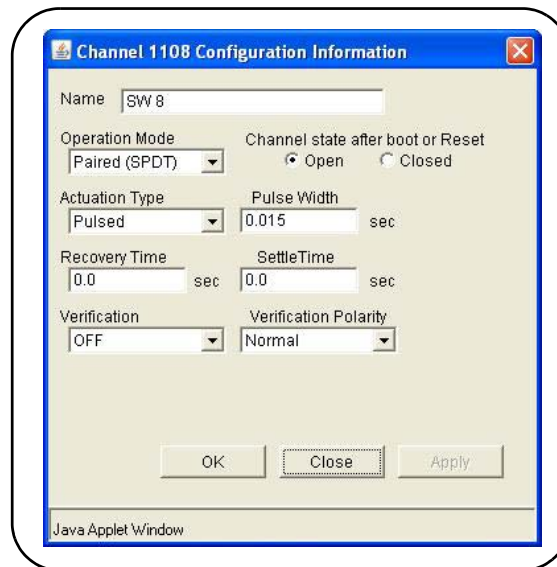

Figure 4-4. The Switch/Attenuator Channel Configuration Window.

The configuration window applies to the **individual** channels on the distribution board. The parameters of this window include:

- **operation mode** - enables channel pairing for dual-coil devices.
- **channel state after boot or Reset** - specifies the channel state (opened, closed) following power-on or reset (assumes boot/reset channel drive state is set).
- **activation type** - specifies pulsed or continuous drive current.
- **pulse width** - specifies the pulse width of the drive current.
- **recovery time** - specifies the period between activation pulses

- **settle time** - specifies the time allowed for the switch/attenuator operation to complete.
- **verification** - enables and disables electronic verification of the programmed switch state.
- **verification polarity** - set the logic polarity of the expected switch position indicator signal.

Bank (Distribution Board) Configuration Window

The distribution board bank configuration window provides settings for the **individual** banks on the 34945EXT.



Figure 4-5. The Bank (Distribution Board) Configuration Window.

These settings include:

- **LED drive control** - enables and disables the distribution board LED drives (LEDs not included) which reflect the position indicator states of the connected switches or attenuators.
- **LED drive level** - sets the amount of current which controls LED brightness.
- **channel drive type** - sets the current drive mode (TTL or Open Collector) for the specified channels.
- **Preset Bank** - this command sets the bank configuration to conform to the switches supported by the distribution board installed. **The programming of any switch or attenuator must begin by presetting the bank.**

Legend

When enabled, channel verification [V] and pairing [P] (channel/attenuator configuration window) are indicated in the channel “bar”. Switch actuation is either continuous or pulsed. Pulsed operation is either open collector (falling edge) or TTL (rising edge).

Bank Diagram

The Bank diagram provides direct switch control (open, close), and identifies channel numbering within the bank and switch status. The channel configuration can also be changed from the preset state as required.

Position Indicator The ‘Position Indicator’ column indicates the state of each switch after the position has been electronically verified. The Agilent switches and attenuators listed in Table 1-2 are latching relays and, therefore, there is a relay coil (channel) for each switch position.

IsOpen/IsClosed This indicator identifies which operation (open or close) was last selected using the channel’s ‘Open’ or ‘Close’ button on the programming diagram. It may not indicate the actual switch state as the switch position is not electronically verified.

SCPI Command Interface

The SCPI programming interface window (Figures 4-2 and 4-6) enables you to send any command in the L4490A/L4491A (34945EXT) SCPI command set to the instrument.

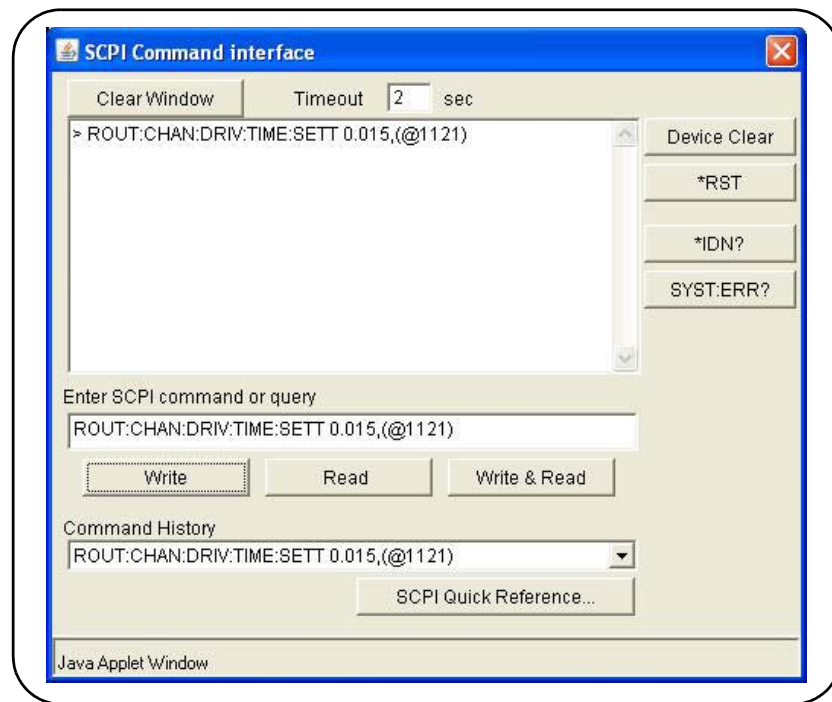

Figure 4-6. Sending Commands from the SCPI Command Interface.

Once the command is entered, selecting ‘Write’ sends the command to the instrument. As mentioned before, commands sent from this interface are also logged (except query commands) and can be copied to other environments.

Logging SCPI Commands

The System Overview window (Figures 4-2 and 4-7) is used to view SCPI commands sent to the instrument as it is configured using the windows of the ‘Browser Web Control Page’. Once the desired configuration is set, the corresponding (logged) commands can be copied and pasted into other development environments.

Commands sent from any IO environment (e.g. Web windows, Agilent Connection Expert Interactive IO, Microsoft development environments) to the instrument are logged. **Query commands (those which return data) sent from any Web interface window are not logged.**

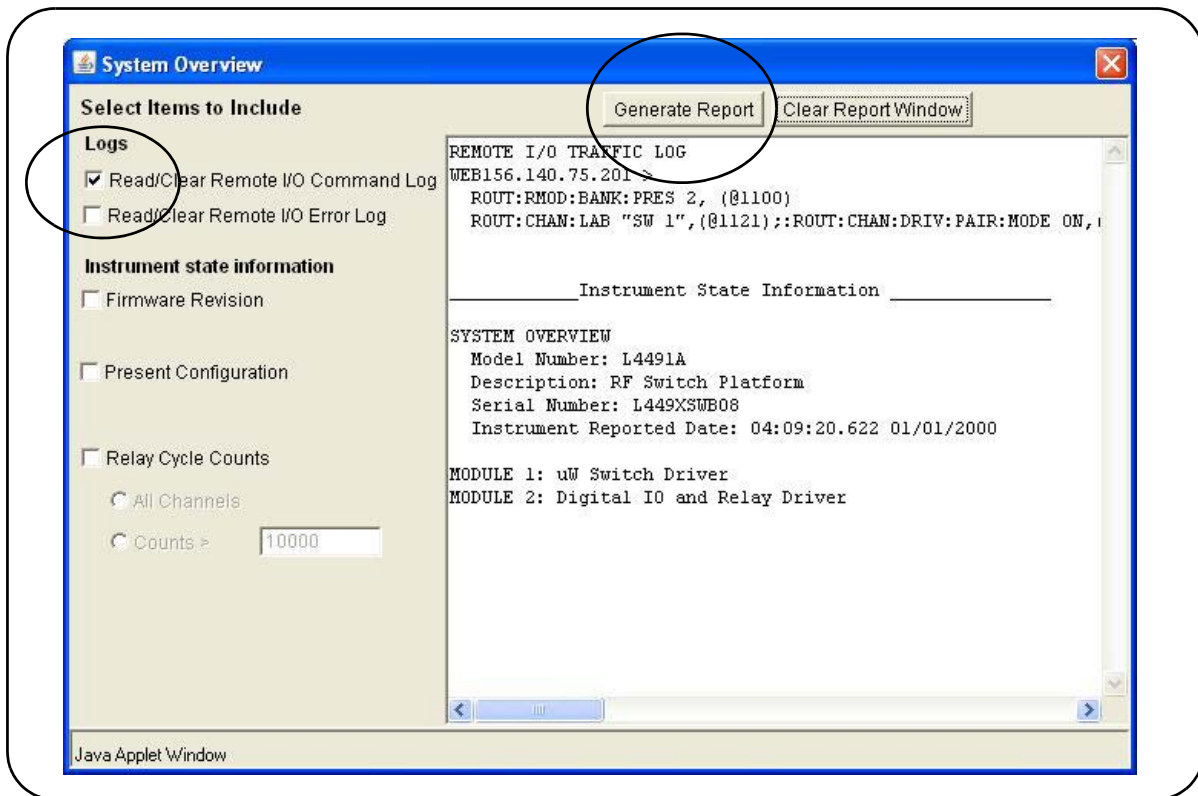

Figure 4-7. Logging SCPI Commands within the System Overview Window.

To view commands, select “Read/Clear Remote I/O Traffic Log” and then select “Generate Report” **after** the desired configuration has been set. Logged commands are listed in the order received by the instrument. Commands may be listed individually or as part of a command string.

Note that when changing the (34945EXT) module, bank, or channel configuration using the windows shown in Figure 4-2, the SCPI commands associated with **all** parameters set by the given window are logged. For example, changing the channel settling time to 15 ms using the bank 2 channel configuration window causes the following string of commands to be logged and sent to the instrument:

```

ROUT:CHAN:LAB "SW 1",(@1121);:ROUT:CHAN:DRIV:PAIR:MODE
ON,(@1121);:ROUT:CHAN:VER:ENAB ON,(@1121);:ROUT:CHAN:VER:POL
NORM,(@1121);:ROUT:CHAN:DRIV:TIME:REC 0.0,(@1121);SETT
0.015,(@1121);:ROUT:CHAN:DRIV:PULS:MODE ON,(@1121);WIDTH
0.015,(@1121);:ROUT:CHAN:DRIV:OPEN:DEF (@1121)

```

If sent individually they would appear as:

```
ROUT:CHAN:LAB "SW 1",(@1121)
ROUT:CHAN:DRIV:PAIR:MODE ON,(@1121)
ROUT:CHAN:VER:ENAB ON,(@1121)
ROUT:CHAN:VER:POL NORM,(@1121)
ROUT:CHAN:DRIV:TIME:REC 0.0,(@1121)
ROUT:CHAN:DRIV:TIME:SETT 0.015,(@1121)
ROUT:CHAN:DRIV:PULS:MODE ON,(@1121)
ROUT:CHAN:DRIV:PULS:WIDTH 0.015,(@1121)
ROUT:CHAN:DRIV:OPEN:DEF (@1121)
```

Again, even though only one parameter (one command) was changed, each of the commands in the string above is sent to the instrument.

System Verification

The most common defects associated with switches and attenuators connected to the 34945EXT through the Y1150A - Y1155A distribution boards are related to switch/attenuator cables.

The optional Y1156A Verification Board is used to provide visual confirmation of the signal path from the PC to distribution board banks 1-4 on the 34945EXT module. Verifying the signal to a selected bank can help isolate suspected problems in the path from the PC to the switch. The diagnostic board also verifies functioning of the electronic position indicator circuitry within the 34945EXT relative to position indicator signals received from the switch.

To begin using the L4490A/L4491A RF switch platform as quickly as possible or to minimize troubleshooting, it is highly recommended that the path to each 34945EXT bank be verified prior to installing the distribution board and any switches or attenuators.

Running the Verification Sequence

The verification sequence is executed from the L4490A/L4491A Web interface. As mentioned in Chapter 3, the L4490A/L4491A must be connected to the PC through one of the LAN configurations shown in Figure 2-1. The Web interface **is not** available from the GPIB interface. To use the Verification Board:

- 1 Turn off the L4490A/L4491A.
- 2 Install the verification board in bank 1 (or the desired bank) of the 34945EXT. Securely fasten the verification board within the bank using the terminal screws.

- 3 Turn on the L4490A/L4491A and open the web interface. Select the 'Browser Web Control' page. See "Getting Started with the L4490A/L4491A Web-Enabled Interface" for instructions on opening the Web page.
- 4 Select 'Allow Full Control' and in the 'Browser Web Control' window, locate the bank and Y1156A programming diagram. An example of the diagram is shown in Figure 4-8.
- 5 From the bank configuration window, select 'Preset Bank'. It may be necessary to turn off the channel drive (module configuration window) before 'Preset Bank' is active.
- 6 From the remote module configuration window, set the Channel Drive source to "Internal" or "External" depending on the 34945EXT supply and select 'Apply'. The Y1156A is designed to use +24V supply.
- 7 Click the "Create Verification Sequence" button. This button defines the verification sequence for the bank and opens the "Sequences..." window. With the defined sequence highlighted, select 'Execute Sequence' to start the sequence. The sequence will pass through the channel list three times. If the signal path to the bank and each channel is complete, the LEDs located on the board will illuminate as each channel in the list is closed.
- 8 Once the sequence completes, set the Channel Drive source to "Off". Move the Y1156A to the next bank. Click the "Update View" button located in the upper-right corner of the 'Browser Web Control' window to refresh the Web page with the new location of the Y1156A. Repeat steps 5-7 to test the signal path to the channels in the next bank.

NOTE

The "Create Verification Sequence" button that appears next to the Y1156 programming diagram is provided only when the Y1156A verification board is installed. The button does not appear with any other distribution board.

Once the verification sequence successfully completes, the sequence can be deleted. The (verification) sequence is defined for the bank each time the "Create Verification Sequence" button is selected.

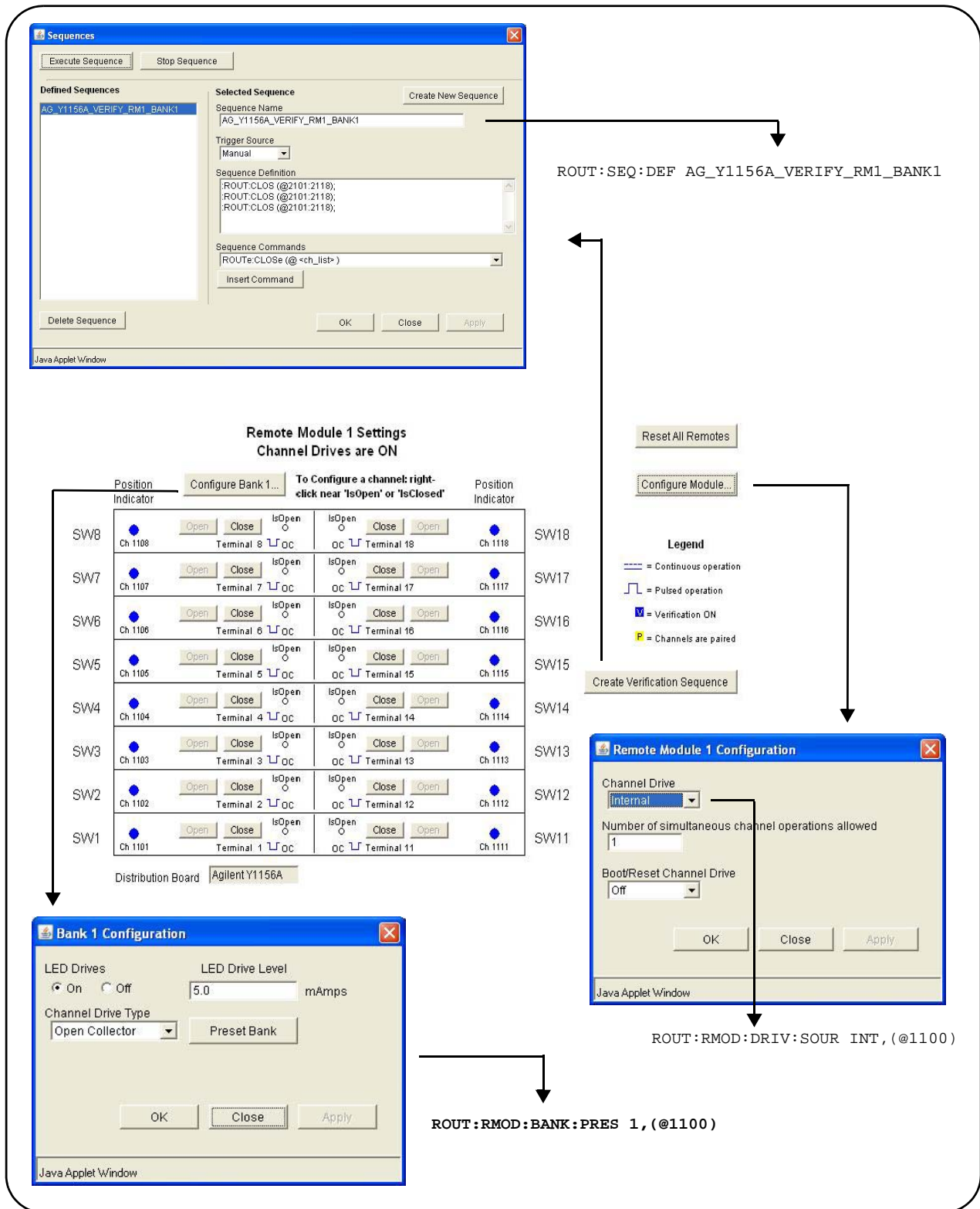

Figure 4-8. Running the Y1156A Verification Sequence.

Position Indicator Verification

Many Agilent switches contain position indicator options that allow for electronic verification of the switch position. The 34945EXT module within the L4490A/L4491A contains circuitry to detect these signals. The Y1156A verification board can be used to test the functioning of this circuitry.

- 1 Turn off the channel drive (module configuration window) or turn off the L4490A/L4491A.
- 2 Install the verification board in bank 1 (or the desired bank) of the 34945EXT. Securely fasten the verification board within the bank using the terminal screws.
- 3 Turn on the L4490A/L4491A (if turned off) and open the web interface. Select the 'Browser Web Control' page and select 'Allow Full Control'.
- 4 In the 'Browser Web Control' window, locate the bank and Y1156A programming diagram. An example of the diagram is shown in Figure 4-9.
- 5 From the bank configuration window, select 'Preset Bank' (the channel drive (module configuration window) must be off before 'Preset Bank' is active).
- 6 Open the 'SCPI Command Interface' window (Figure 4-9) and from the window, send the commands:

```
ROUT:CHAN:VER:ENAB ON,(@1101:1118)      !enable verification
ROUT:CHAN:VER:POL INV,(@1101:1118)      !invert the polarity
ROUT:CHAN:DRIV:PULS:MODE OFF,(@1101:1118) !continuous drive
```

- 7 Create a verification sequence (see "Sequence Programming") that closes and opens the desired channel(s). Enable the channel drive and execute the sequence. With the polarity inverted (Step 6), closing the channel tests the 34945EXT circuitry receiving the position indication signal. An error message will occur if the position sensed does not correspond to the programmed state.
- 8 To verify other channels, modify the channel address in the sequence as required and execute the sequence again. To test another bank, set the Channel Drive source to "Off". Move the Y1156A to the bank and click the "Update View" button to refresh the Web page. Repeat steps 5-6 (with the new bank address) and change the channel addresses in the sequence.

When finished with the verification, turn off the continuous current mode to prevent an overcurrent condition on the power supply driving the 34945EXT.

The figure illustrates the software interface for configuring and executing a sequence on the Y1156A. It consists of several interconnected windows and panels:

- Sequences Window:** Shows a list of defined sequences. The selected sequence is "POS_IND_VERIFY". Its definition includes commands for opening and closing channels 1101, 1102, and 1103. The sequence commands are set to "ROUTE:Close (@<ch_list*)".
- SCPI Command interface:** Displays the command history, including "ROUTE:CHAN:DRIV:PULS:MODE OFF,(@1101:1118)".
- Main Control Panel:** Features buttons for "Observe Only" and "Allow Full Control" (selected), along with "Sequences...", "System Overview...", "Commands...", and "Update View".
- Microwave Switch/Attenuator Driver:** Shows "Remote Module 1 Settings" with a table of channels (SW1 to SW8) and their terminals. A legend defines symbols for continuous operation, pulsed operation, verification ON, and paired channels.
- Bank 1 Configuration:** A dialog box for setting LED drives and channel drive type. It is linked to the command "ROUTE:RMOD:BANK:PRES 1, (@1100)".
- Remote Module 1 Configuration:** A dialog box for setting channel drive and boot/reset options. It is linked to the command "ROUTE:RMOD:DRIV:SOUR INT, (@1100)".

Figure 4-9. Using the Y1156A for Position Indicator Verification.

Switch and Attenuator Programming

This section covers programming of switches/attenuators (Table 1-2) from the Web interface. The Web interface is used to demonstrate setting preset states that are optimized for the switches supported by the distribution boards.

NOTE

The information in this section does not cover the entire instrument command set. Refer to Chapter 5 for a complete list of instrument commands and to the Programmer's Reference on the Product Reference CD-ROM for detailed information.

Agilent N1810/N1811/N1812 Series Switches

The Agilent N1810 / N1811 / N1812 series switches are supported on the following distribution board:

- Y1150A
 - N18xx series (eight switches)

The bank diagram is shown in Figure 4-10.

Presetting the Bank

In order to preset the banks on the 34945EXT module (the programming of any switch or attenuator must begin with the preset state), 'Allow Full Control' (Figure 4-2) must be selected and the module's channel drive must be **off** (Configure Module... button).

To set the preset values for the N181x series switches (Figure 4-10), select 'Preset Bank' in the Bank Configuration window. Presetting the bank is equivalent to sending the SCPI commands shown, or to configuring the switches to the settings indicated in the bank, module, and channel configuration windows.

Changing Settings and Enabling the Channel Drive

Following the preset, use the bank configuration and channel configuration windows (Figure 4-10) to change the preset settings as required. The SCPI Command Interface window can also be used to send commands to the instrument.

When complete, use the module configuration window to enable the channel drive. (If L4491A Option 002 is installed, the channel drive source must be set to EXTERNAL for the second 34945EXT - remote module 2.) Use the bank diagram to control (open/close) the switches (see "Y1150A Switch Control" in Chapter 5 for more information).

Settings (commands) from any of these sources can be logged for transfer to other programming environments (see "Logging SCPI Commands").

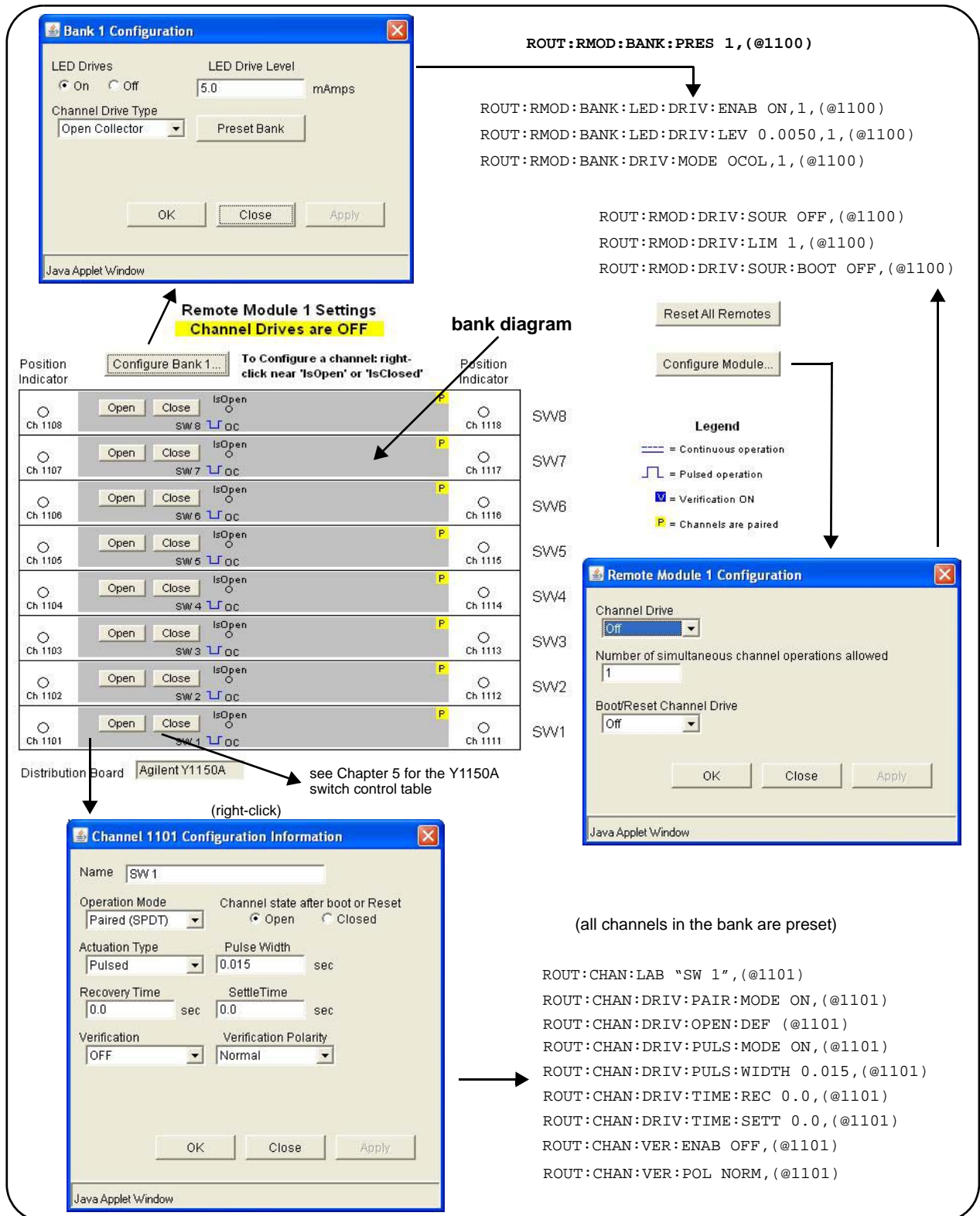

Figure 4-10. Y1150A Distribution Board Web User Interface Preset State.

Agilent 87104/87106/87406 - L7104/L7106/L7204/L7206 Switches

The Agilent 87104/87106/87406 series and L7104/L7106/L7204/L7206 series switches are supported on the following distribution board:

- Y1151A
 - 87xxx series and L7xxx series (two switches)

The bank diagram is shown in Figure 4-11.

Presetting the Bank

In order to preset any of the banks on the 34945EXT module (the programming of any switch or attenuator must begin with the preset state), 'Allow Full Control' (Figure 4-2) must be selected and the module's channel drive must be **off** (Configure Module... button).

To set the preset values for the 87xxx and L7xxx series switches (Figure 4-11), select 'Preset Bank' in the Bank Configuration window. All switches supported on this distribution board have the same preset settings. Presetting the bank is equivalent to sending the SCPI commands shown, or to configuring the switches to the settings indicated in the bank, module, and channel configuration windows.

Changing Settings and Enabling the Channel Drive

Following the preset, use the bank configuration and channel configuration windows (Figure 4-11) to change the preset settings as required. The SCPI Command Interface window can also be used to send commands to the instrument.

When complete, use the module configuration window to enable the channel drive. (If L4491A Option 002 is installed, the channel drive source must be set to EXTERNAL for the second 34945EXT - remote module 2.) Use the bank diagram to control (open/close) the switches (see "Y1151A Switch Control" in Chapter 5 for more information).

Settings (commands) from any of these sources can be logged for transfer to other programming environments (see "Logging SCPI Commands").

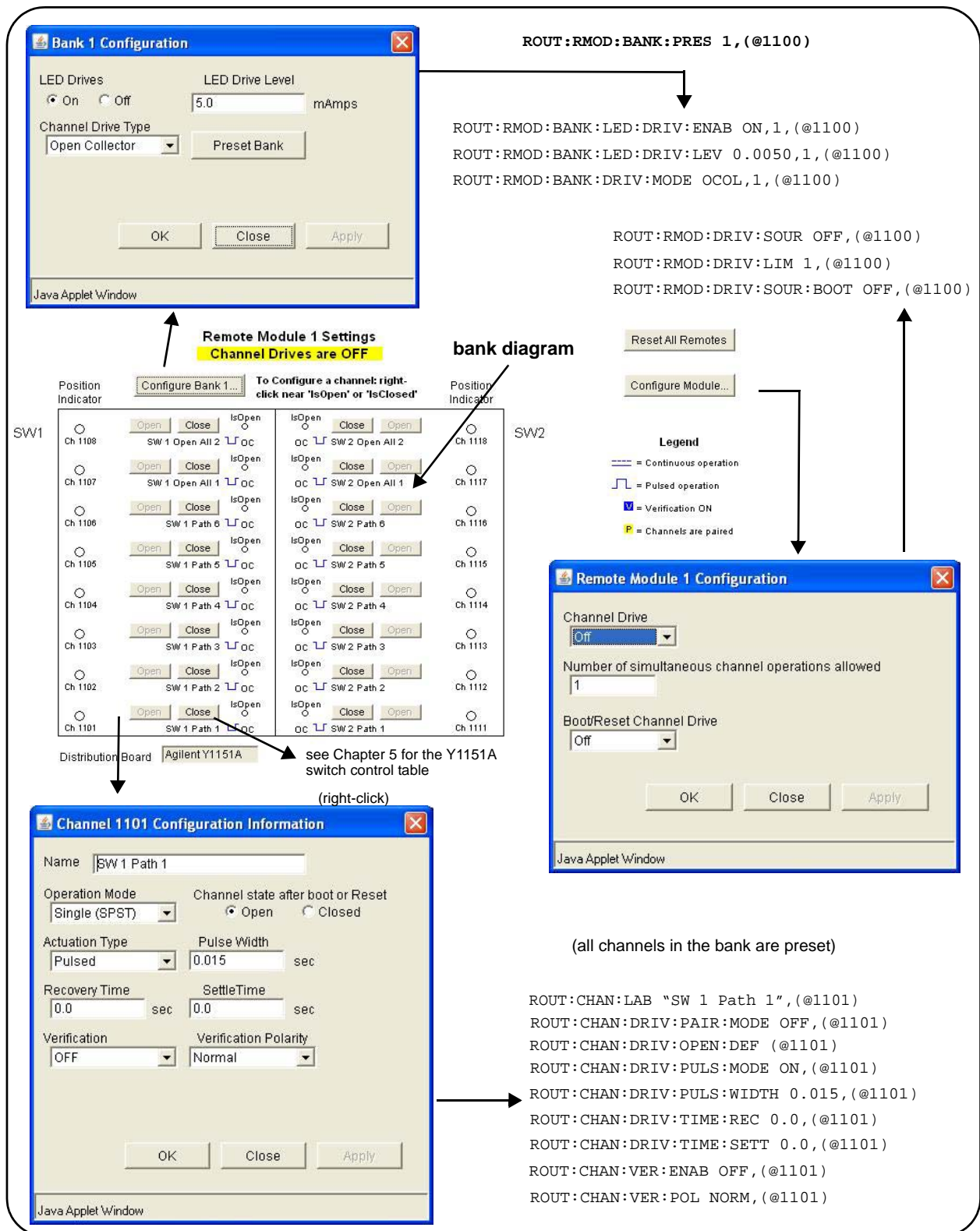

Figure 4-11. Y1151A Distribution Board Web User Interface Preset State.

Agilent 87204 / 87206 Series and 87606 Switches

The Agilent 87204/87206 series and 87606 switches are supported on the following distribution board:

- Y1152A
 - 87204/87206 series and 87606 (one switch)
 - N181x series (two switches)

The bank diagram applies to both types of switches. The diagram is shown in Figure 4-12.

Presetting the Bank

In order to preset any of the banks on the 34945EXT module (the programming of any switch or attenuator must begin with the preset state), 'Allow Full Control' (Figure 4-2) must be selected and the module's channel drive must be **off** (Configure Module... button).

To set the preset values for the N181x series, the 872xx series, and 87606 switches (Figure 4-12), select 'Preset Bank' in the Bank Configuration window. Presetting the bank is equivalent to sending the SCPI commands shown, or to configuring the switches to the settings indicated in the bank, module, and channel configuration windows.

Changing Settings and Enabling the Channel Drive

Following the preset, use the bank configuration and channel configuration windows (Figure 4-12) to change the preset settings as required. The SCPI Command Interface window can also be used to send commands to the instrument.

When complete, use the module configuration window to enable the channel drive. (If L4491A Option 002 is installed, the channel drive source must be set to EXTERNAL for the second 34945EXT - remote module 2.) Use the bank diagram to control (open/close) the switches (see "Y1152A Switch Control" in Chapter 5 for more information).

Settings (commands) from any of these sources can be logged for transfer to other programming environments (see "Logging SCPI Commands").

Bank 1 Configuration

LED Drives: On Off LED Drive Level: 5.0 mAmps

Channel Drive Type: Open Collector Preset Bank

OK Close Apply

Remote Module 1 Settings
Channel Drives are OFF

bank diagram

Position Indicator: Ch 1108 to Ch 1101 (left) and Ch 1118 to Ch 1111 (right)

SW3, SW2, SW1 labels

Legend:
 --- = Continuous operation
 [Square Wave] = Pulsed operation
 [V] = Verification ON
 [P] = Channels are paired

Remote Module 1 Configuration

Channel Drive: Off

Number of simultaneous channel operations allowed: 1

Boot/Reset Channel Drive: Off

OK Close Apply

Channel 1101 Configuration Information

Name: SW 1 Path 1

Operation Mode: Paired (SPDT) Channel state after boot or Reset: Open Closed

Actuation Type: Pulsed Pulse Width: 0.015 sec

Recovery Time: 0.0 sec SettleTime: 0.0 sec

Verification: OFF Verification Polarity: Inverted

OK Close Apply

ROUT:RMOD:BANK:PRES 1, (@1100)

```

ROUT:RMOD:BANK:LED:DRIV:ENAB ON,1,(@1100)
ROUT:RMOD:BANK:LED:DRIV:LEV 0.0050,1,(@1100)
ROUT:RMOD:BANK:DRIV:MODE OCOL,1,(@1100)

ROUT:RMOD:DRIV:SOUR OFF,(@1100)
ROUT:RMOD:DRIV:LIM 1,(@1100)
ROUT:RMOD:DRIV:SOUR:BOOT OFF,(@1100)
    
```

ROUT:CHAN:LAB "SW 1 Path 1", (@1101)

```

ROUT:CHAN:DRIV:PAIR:MODE ON,(@1101)
ROUT:CHAN:DRIV:CLOS:DEF (@1101)
ROUT:CHAN:DRIV:PULS:MODE ON,(@1101)
ROUT:CHAN:DRIV:PULS:WIDTH 0.015,(@1101)
ROUT:CHAN:DRIV:TIME:REC 0.0,(@1101)
ROUT:CHAN:DRIV:TIME:SETT 0.0,(@1101)
ROUT:CHAN:VER:ENAB OFF,(@1101)

SW1 = ROUT:CHAN:VER:POL INV,(@1101)
SW2 / SW3 = ROUT:CHAN:VER:POL NORM,(@1101)
    
```

Figure 4-12. Y1152A Distribution Board Web User Interface Preset State.

Agilent 8490x Series / 849x Series Attenuators and 876xM Series Switches

The Agilent 8490x series and 849x series attenuators, and the 876xM series switches are supported on the following distribution board:

- Y1153A
 - 8490x series (two attenuators - if no switch connected)
 - 849x series (two attenuators - if no switch connected)
 - 876xM series (two switches - if no attenuator connected
 - one 8769M)

The bank diagram shown in Figure 4-13 represents attenuators that have four sections of attenuation. See Figures 2-7 and 2-8 for attenuation guides.

Presetting the Bank

In order to preset any of the banks on the 34945EXT module (the programming of any switch or attenuator must begin with the preset state), 'Allow Full Control' (Figure 4-2) must be selected and the module's channel drive must be **off** (Configure Module... button).

To set the preset values for the 8490x series / 849x series attenuators and 876xM series switches (Figure 4-13), select 'Preset Bank' in the Bank Configuration window. All attenuators supported on this distribution board have the same preset settings. Presetting the bank is equivalent to sending the SCPI commands shown, or to configuring the attenuators to the settings indicated in the bank, module, and channel configuration windows.

Changing Settings and Enabling the Channel Drive

Following the preset, use the bank configuration and channel configuration windows (Figure 4-13) to change the preset settings as required. The SCPI Command Interface window can also be used to send commands to the instrument.

When complete, use the module configuration window to enable the channel drive. (If L4491A Option 002 is installed, the channel drive source must be set to EXTERNAL for the second 34945EXT - remote module 2.) Use the bank diagram to control the levels of attenuation (see "Y1153A Switch Control" in Chapter 5 for more information).

Settings (commands) from any of these sources can be logged for transfer to other programming environments (see "Logging SCPI Commands").

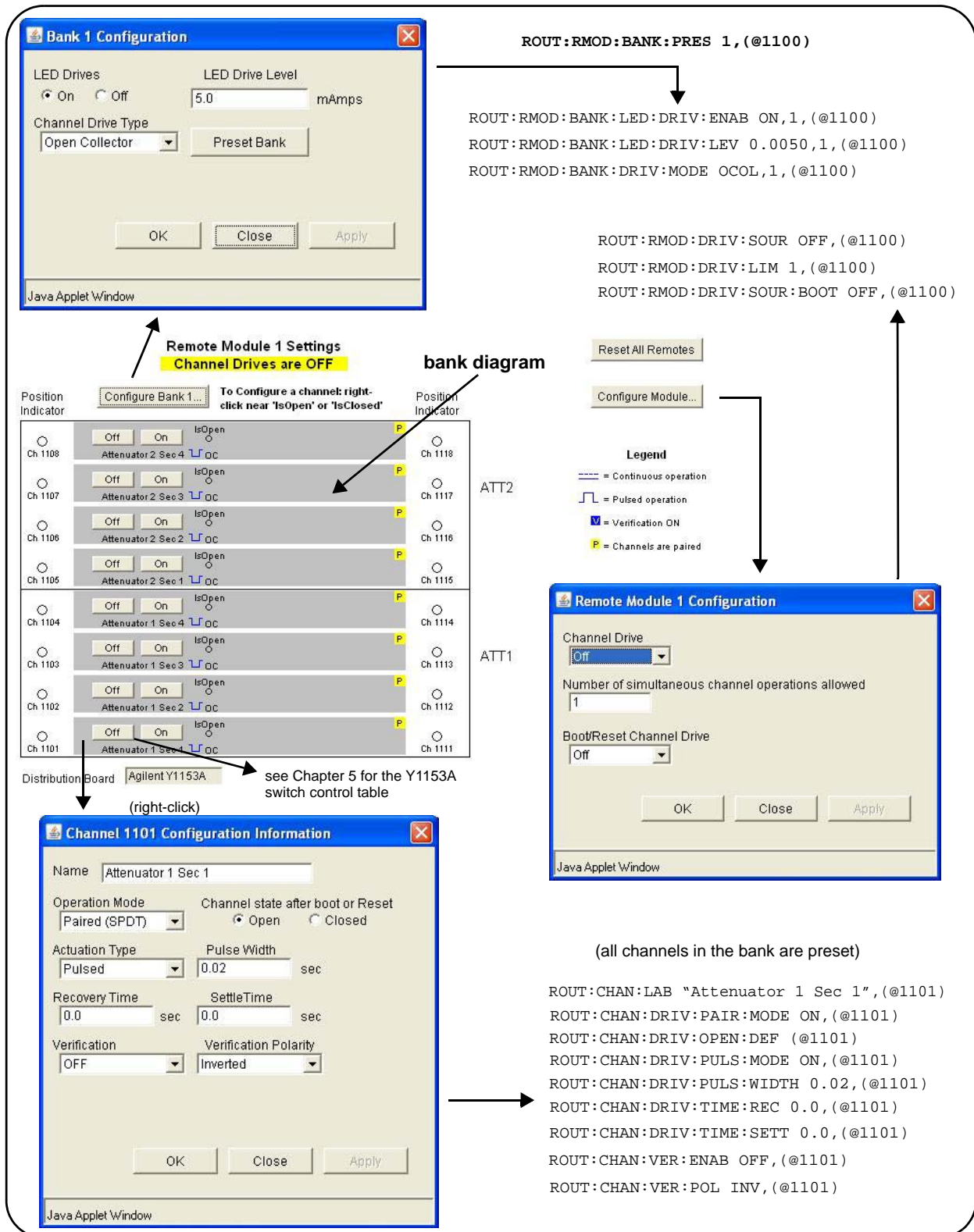

Figure 4-13. Y1153A Distribution Board Web User Interface Preset State.

Agilent 87222 Series and L7222C Switches

The Agilent 87222 series and L7222C switches are supported on the following distribution board:

- Y1154A
 - 87222 series, L7222C (two switches)
 - N18xx series (six switches)

The bank diagram applies to both types of switches and is shown in Figure 4-14.

Presetting the Bank

In order to preset the banks on the 34945EXT module (the programming of any switch or attenuator must begin with the preset state), 'Allow Full Control' (Figure 4-2) must be selected and the module's channel drive must be **off** (Configure Module... button).

To set the preset values for the 87222 series, the L7222C, and the N181x series switches (Figure 4-14), select 'Preset Bank' in the Bank Configuration window. All switches supported on these distribution boards have the same preset settings. Presetting the bank is equivalent to sending the SCPI commands shown, or to configuring the switches to the settings indicated in the bank, module, and channel configuration windows.

Changing Settings and Enabling the Channel Drive

Following the preset, use the bank configuration and channel configuration windows (Figure 4-14) to change the preset settings as required. The SCPI Command Interface window can also be used to send commands to the instrument.

When complete, use the module configuration window to enable the channel drive. (If L4491A Option 002 is installed, the channel drive source must be set to EXTERNAL for the second 34945EXT - remote module 2.) Use the bank diagram to control (open/close) the switches (see "Y1154A Switch Control" in Chapter 5 for more information).

Settings (commands) from any of these sources can be logged for transfer to other programming environments (see "Logging SCPI Commands").

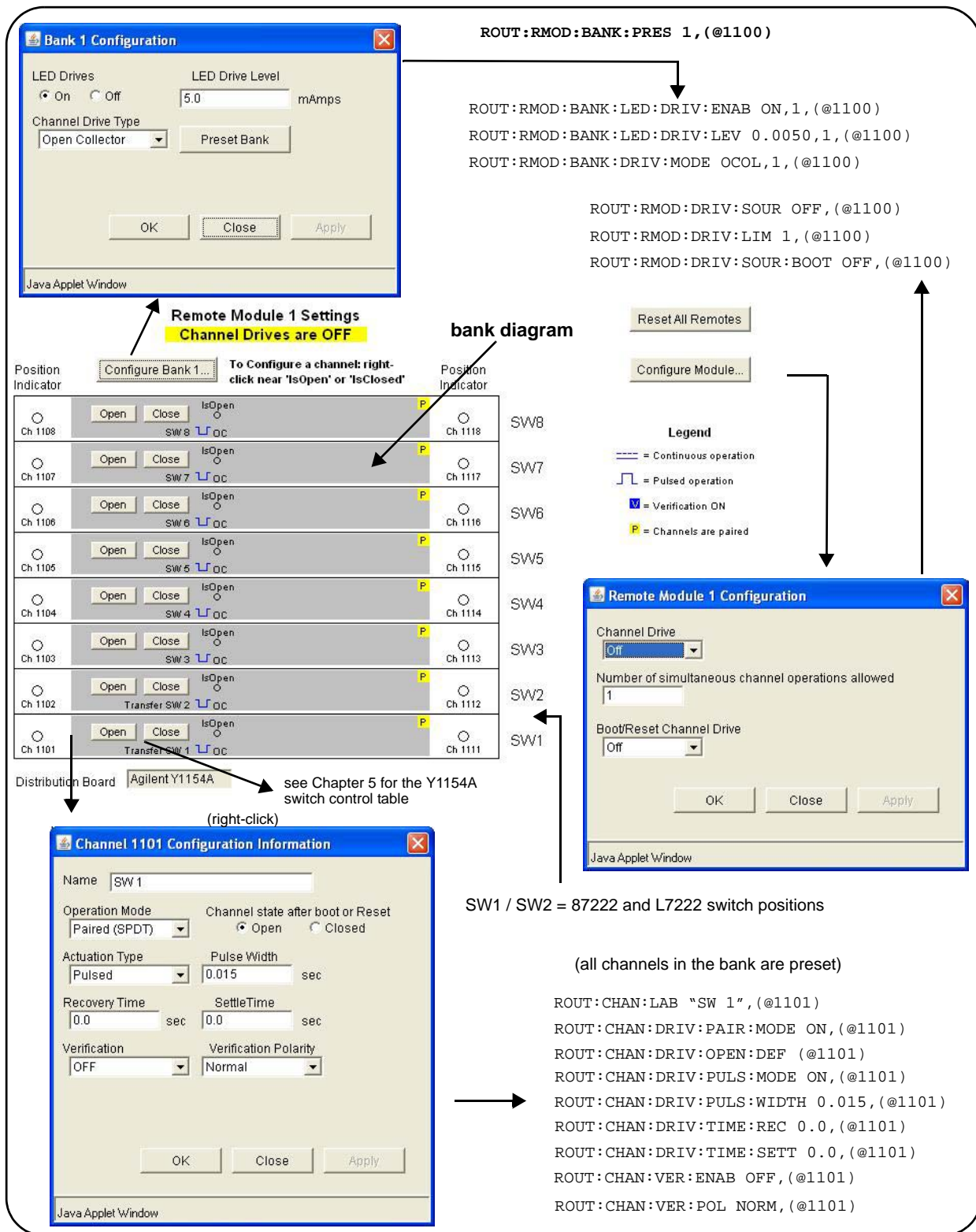

Figure 4-14. Y1154A Distribution Board Web User Interface Preset State.

Agilent 876x Series and U9397A/C Switches

The Agilent 876x series and U9397A/C switches are supported on the following distribution board:

- Y1155A
 - 8762/8763/8764/8765 series (eight switches)
 - 8766/8767 K series (two switches)
 - 8768/8769 K series (one switch)

 - U9397A/C (sixteen switches)

The bank diagram applies to all series of switches. The diagram is shown in Figure 4-15.

Presetting the Bank

In order to preset any of the banks on the 34945EXT module (the programming of any switch or attenuator must begin with the preset state), 'Allow Full Control' (Figure 4-2) must be selected and the module's channel drive must be **off** (Configure Module... button).

To set the preset values for the 876x series and U9397A/C switches (Figure 4-15), select 'Preset Bank' in the Bank Configuration window. All switches supported on this distribution board have the same preset settings. Presetting the bank is equivalent to sending the SCPI commands shown, or to configuring the switches to the settings indicated in the bank, module, and channel configuration windows.

Changing Settings and Enabling the Channel Drive Source

Following the preset, use the bank configuration and channel configuration windows (Figure 4-15) to change the preset settings as required. The SCPI Command Interface window can also be used to send commands to the instrument.

When complete, use the module configuration window to enable the channel drive. (If L4491A Option 002 is installed, the channel drive source must be set to EXTERNAL for the second 34945EXT - remote module 2.) Use the bank diagram to control (open/close) the switches (see "Y1155A Switch Control" in Chapter 5 for more information).

Settings (commands) from any of these sources can be logged for transfer to other programming environments (see "Logging SCPI Commands").

Using other Agilent Switches with the Y1155A Distribution Board

Any of the Agilent switches and attenuators listed in Table 1-2 can be used with the Y1155A distribution board. From the SCPI command Interface window, the preset settings for a given switch or attenuator can be set by sending the corresponding SCPI command for each preset value.

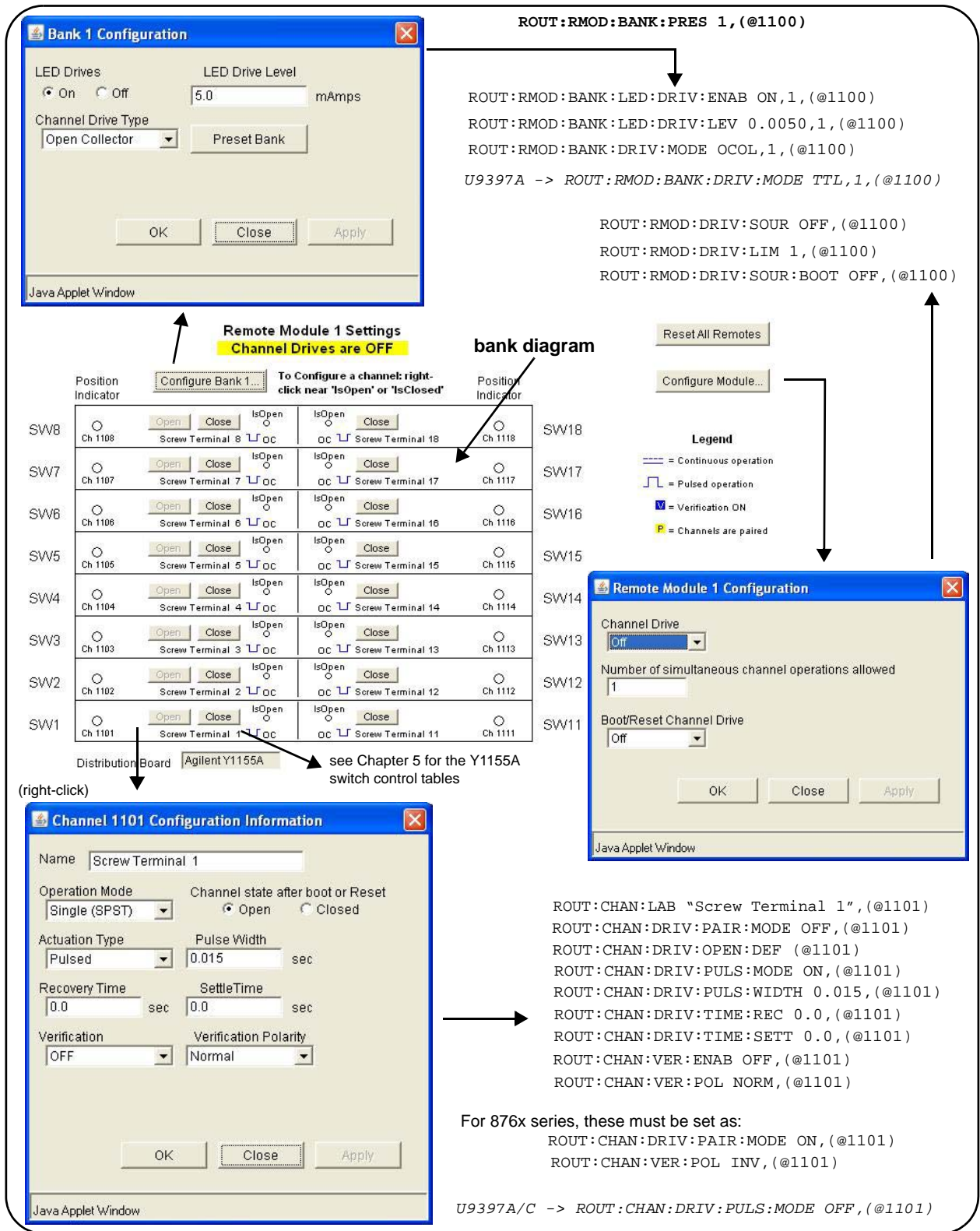

Figure 4-15. Y1155A Distribution Board Web User Interface Preset State.

Sequence Programming

A programming sequence is a set of commands that provide direct control (open, close, delay) of switches and attenuators. The advantages of using programming sequences are:

- a sequence can be given a descriptive name indicating its function or the signal path it is controlling
- programming speed is increased (IO - input/output transactions decreased)
- channel operations (delay/open/close) occur precisely and in the channel list order specified

A programming sequence can be defined using the Sequences window opened with the Sequences... button on the 'Browser Web Control' page (Figure 4-2). The Sequences window is shown in Figure 4-16.

Defining a Sequence

Sequences are defined by a sequence name, trigger source, and definition (the commands within the sequence). The commands allowed **within** a sequence are listed in the 'Sequence Commands' drop-down box and include:

```
ROUTE:CLOSE (@<ch_list>)
ROUTE:OPEN (@<ch_list>)
ROUTE:MODULE:WAIT <slot>|ALL
ROUTE:SEQUENCE:TRIGGER[:IMMEDIATE] <sequence_name>
SYSTEM:DELAY[:IMMEDIATE] <time_in_seconds>
ABORT
```

Additional guidelines when using sequences include:

- 1 Sequences are stored in the non-volatile memory of the 34945EXT.
- 2 Up to 500 sequences can be stored; each sequence must be ≤ 1024 bytes.
- 3 Sequences can be nested (one sequence can start another).
- 4 Sequences are not deleted with `SYSTEM:RMODULE:RESet`
- 5 Renaming a sequence creates a new sequence by that name.
- 6 Defined sequences can be logged for transfer to other programming environments (see "An Overview of the 'Browser Web Control' Page").

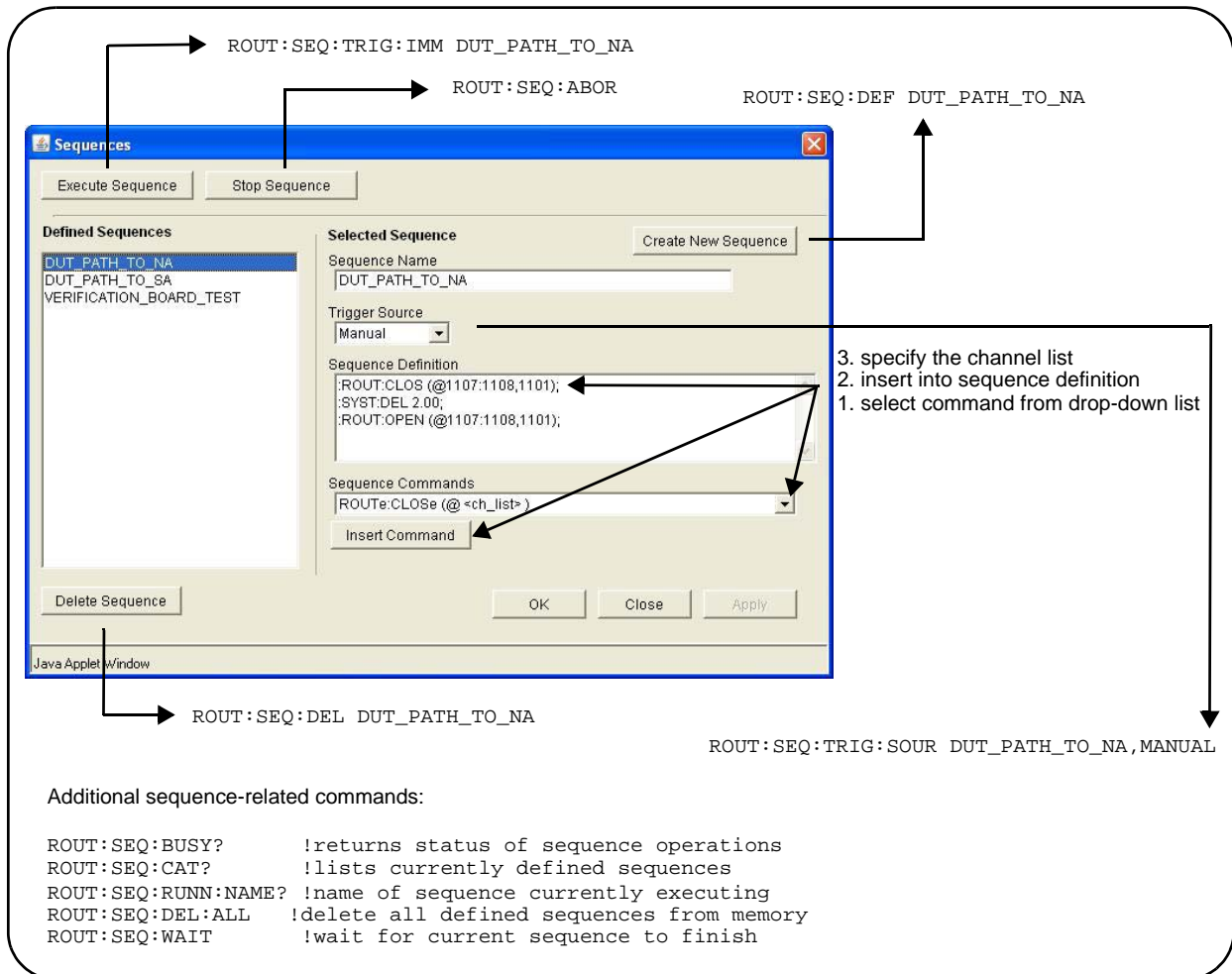

Figure 4-16. Defining Programming Sequences with the Sequences Window.

NOTE

Refer to the L4490A/L4491A Product Reference CD-ROM for more information on the RF switch platform sequence-related commands.

Using L4490A/L4491A Digital IO and Relay Driver Option 004

Option 004 to the L4490A and L4491A adds 16-bits of digital (general purpose) IO and 28 relay control lines to the RF switch platform. The location of the Option 004 module is shown in Figure 2-1.

Connector Pin Definitions

The Option 004 connectors and pin definitions are shown on the following page and in Table 4-1. The Web user interface is shown in Figure 4-17.

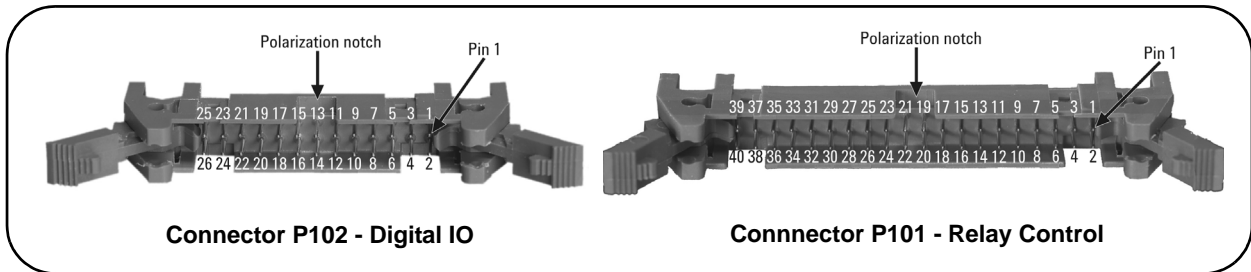

Table 4-1. L4490A/L4491A Option 004 Pin Definitions.

Connector P102 (Digital IO) Pin Definitions			
1	Relay Ground	14	Channel 2001; Bit 5
2	Channel 2002; Bit 7	15	Channel 2001; Bit 4
3	Channel 2002; Bit 6	16	+5V power supply
4	Channel 2002; Bit 5	17	Channel 2001; Bit 3
5	Channel 2002; Bit 4	18	Channel 2001; Bit 2
6	+5V power supply	19	Channel 2001; Bit 1
7	Channel 2002; Bit 3	20	Channel 2001; Bit 0
8	Channel 2002; Bit 2	21	Relay Ground
9	Channel 2002; Bit 1	22	Control Line 1: Channel 1 Strobe Line
10	Channel 2002; Bit 0	23	Control Line 2: Channel 2 Strobe Line
11	Relay Ground	24	Control Line 3: Read/Write Status Line
12	Channel 2001; Bit 7	25	+5V power supply
13	Channel 2001; Bit 6	26	Relay Ground
Connector P101 (Relay Control) Definitions			
1	Not used	21	+12V power supply
2	Not used	22	Not used
3	Not used	23	Not used
4	Not used	24	Not used
5	Channel 2128 (gen. purpose relay drive)	25	Channel 2116 (gen. purpose relay drive)
6	Channel 2127 (gen. purpose relay drive)	26	Channel 2115 (gen. purpose relay drive)
7	Channel 2126 (gen. purpose relay drive)	27	Channel 2114 (gen. purpose relay drive)
8	Channel 2125 (gen. purpose relay drive)	28	Channel 2113 (gen. purpose relay drive)
9	Channel 2124 (gen. purpose relay drive)	29	Channel 2112 (gen. purpose relay drive)
10	Channel 2123 (gen. purpose relay drive)	30	Channel 2111 (gen. purpose relay drive)
11	Channel 2122 (gen. purpose relay drive)	31	Channel 2110 (gen. purpose relay drive)
12	Channel 2121 (gen. purpose relay drive)	32	Channel 2109 (gen. purpose relay drive)
13	Channel 2120 (gen. purpose relay drive)	33	Channel 2108 (gen. purpose relay drive)
14	Channel 2119 (gen. purpose relay drive)	34	Channel 2107 (gen. purpose relay drive)
15	Channel 2118 (gen. purpose relay drive)	35	Channel 2106 (gen. purpose relay drive)
16	Channel 2117 (gen. purpose relay drive)	36	Channel 2105 (gen. purpose relay drive)
17	Not used	37	Channel 2104 (gen. purpose relay drive)
18	Not used	38	Channel 2103 (gen. purpose relay drive)
19	Not used	39	Channel 2102 (gen. purpose relay drive)
20	+12V power supply	40	Channel 2101 (gen. purpose relay drive)

The screenshot displays the Agilent Technologies L4490A / 91A RF Switch Platform web user interface. The main window is titled "Digital IO and Relay Driver" and shows two channels: Channel 2001 (Control_1) and Channel 2002 (DIO BYTE 2). Channel 2001 is configured as an output with a width of 1 byte and output data of 0xAA. Channel 2002 is configured as an input with a width of 1 byte. A grid of 28 digital IO lines (2108-2128) is shown, with line 2107 labeled "actuate".

Two configuration windows are shown:

- Channel 2001 Configuration:** Name: Control_1, Direction: Output, Width: 1 byte.
- Channel 2101 Configuration:** Name: actuate.

Two data windows are shown:

- Read/Write Digital Data:** Channel: 2001, Width: 1 Byte, Data: AA, Hex format.
- Channel 2101 Configuration:** Name: actuate.

Terminal commands are shown on the right side of the interface:

```

ROUT:CHAN:LAB "Control_1", (@2001)
SOUR:DIG:STAT 1,(@2001) !channel output
SOUR:DIG:STAT 0,(@2001) !channel input
CONF:DIG:WIDTH BYTE, (@2001)
CONF:DIG:WIDTH WORD, (@2001) !combines channels
    
```

Additional terminal commands shown are:

```

SYST:CPON 2
ROUT:OPEN:ALL 2
ROUT:OPEN (@2107)
ROUT:CLOS (@2107)
ROUT:CHAN:LAB "actuate", (@2101)
    
```

Annotations include arrows pointing from the configuration windows to the main interface, and from the main interface to the data windows. A note indicates that a right-click on the actuate line in the grid leads to the Channel 2101 Configuration window.

Figure 4-17. L4490A / L4491A Option 004 Web User Interface.

NOTE

Connector cables are not provided with L4490A/L4491A Option 004.

Configuring the Digital IO and Relay Drive Lines

Unlike the distribution boards used with the L4490A and L4491A, Option 004 is not configured from a “preset” state. However, resetting the module will set the operation mode of the digital (general purpose) IO to “input”, the width of the input pattern to one byte, and open all relay drive channels. User-defined channel labels remain unchanged.

Use the ‘channel configuration’ window (Figure 4-17) to set the direction (operation mode) of the digital pattern and the width of the pattern (one or two bytes). Use the ‘read/write digital data’ window read the data on the input lines and to set the output pattern in decimal, binary, or hexadecimal format.

Clicking on the relay drive channel number or switch opens/closes the switch. Note that each channel can sink up to 100 mA (low-side drive).

Settings (commands) from any of these sources can be logged for transfer to other programming environments (see “Logging SCPI Commands”).

Query commands (those which return data - i.e. Read) are not logged.

NOTE

Refer to Chapter 5 for more information on the digital IO option and a summary of related commands. Refer to the L4490A/L4491A Product Reference CD-ROM for detailed information on the commands.

Power-On, *RST, and SYSTEM:CPON States

Cycling power or resetting the L4490A/L4491A (*RST, SYSTEM:CPON commands) restores user-specified default states, but otherwise maintains preset or individually-set switch or attenuator settings. The default states restored are those specified with the commands:

```
ROUTE:CHANnel:DRIVE:CLOSE:DEFault !channel settings
ROUTE:CHANnel:DRIVE:OPEN:DEFault
ROUTE:RMOdule:DRIVE:SOURce:BOOT !drive current-ON, OFF,
EXTernal
```

All other switch/attenuator settings in place prior to the power cycle or reset event remain unchanged. These events, however, do cause the 34945EXT to recognize new topologies (external switches, power configurations).

NOTE

If a channel is configured for a single drive in pulsed mode, OPEN operations are undefined. When these channels are configured to a default state of OPEN, no action is taken on these channels.

The Web Interface 'Reset All Remotes' Button

The 'Reset All Remotes' button located to the right of the switch or attenuator (Web interface) programming diagram resets all distribution board settings to their user-specified default states, preset settings, and individually-set switch or attenuator settings. This button is equivalent to the SCPI command:

```
SYSTem:CPON <remote module #>
```

Restoring L4490A/L4491A Factory Settings

Factory settings for the L4490A/L4491A configuration and all installed distribution boards are restored with the command:

```
SYSTem:RMOdule:RESet 1
```

This command and its subsequent settings override any previously stored preset, default, and power-on or reset settings. The factory settings grouped according to 34945EXT, bank, and channel are shown in Table 4-2.

Table 4-2. L4490A/L4491A Factory Settings.

Parameter	Command	Setting
	34945EXT Settings	
Channel Drive Source	ROUTe:RMOdule:DRIVe:SOURce:IMMediate	OFF
Boot/Reset Channel Drive	ROUTe:RMOdule:DRIVe:SOURce:BOOT	OFF
Simultaneous Operations	ROUTe:RMOdule:DRIVe:LIMit	1
	Bank Settings	
Channel Drive Type	ROUTe:RMOdule:BANK:DRIVe:MODE	OCOLlector
LED Drives	ROUTe:RMOdule:BANK:LED:DRIVe:ENABle	ON
LED Drive Level	ROUTe:RMOdule:BANK:LED:DRIVe:LEVel	5 mA
	Channel Settings	
Operation Mode	ROUTe:CHANnel:DRIVe:PAIRed:MODE	OFF
Actuation Type	ROUTe:CHANnel:DRIVe:PULSe:MODE	ON
Pulse Width	ROUTe:CHANnel:DRIVe:PULSe:WIDTh	15 ms
Recovery Time	ROUTe:CHANnel:DRIVe:TIME:RECOvery	0.0 seconds
Settle Time	ROUTe:CHANnel:DRIVe:TIME:SETTle	0.0 seconds
Channel State (after boot or reset)	ROUTe:CHANnel:DRIVe:OPEN:DEFault	OPEN
Verification	ROUTe:CHANnel:VERify:ENABle	OFF
Verification Polarity	ROUTe:CHANnel:VERify:POLarity	NORMal

4 Introduction to Programming



5 Additional Operating Information

L4490A/L4491A SCPI Command Summary	100
Y1150A - Y1155A Switch Control Tables	104
Y1150A Switch Control	104
Y1151A Switch Control	104
Y1152A Switch Control	105
Y1153A Switch Control	106
Y1154A Switch Control	106
Y1155A Switch Control	107
Drive Modes	109
Using Single-Coil Switches and Attenuators	110
Continuous Drive Mode	110
Single Coil with Separate Position Indicators Connection Diagram	111
Using Dual-Coil Switches and Attenuators	112
Pairing Channels	113
Paired Drive With Separate Position Indicators	113
Paired Drive With Combined Position Indicators	114
Pulsed Actuation Mode	115
Overcurrent Conditions	117
Command Execution Times	118
Verifying Switch States	119
LED Drive Indicators	120
L4490A/L4491A Digital IO and Relay Driver Option 004	121

This chapter contains additional information on selected topics covered in Chapters 1-4. Refer to this chapter for specific information on:

- the L4490A/L4491A command summary
- switch control tables
- open collector (OC) and TTL drive modes
- single- and dual-coil switches and attenuators
- continuous vs. pulsed drive modes
- overcurrent conditions
- factors related to command execution times



L4490A/L4491A SCPI Command Summary

Table 5-1 lists the SCPI commands that apply to the L4490A/L4491A RF Switch Platform.

As not all commands are covered in this manual, refer to the Programmer's Reference contained on the L4490A/L4491A Product Reference CD-ROM (p/n L4490-13601) for detailed information on the complete SCPI command set.

Table 5-1. L4490A/L4491A SCPI Command Summary.

Subsystem	Commands
<p style="text-align: center;">ROUTE (Switch Control)</p>	<p>ROUTE:CHANnel:DRIVE:CLOSE:DEFault (@<ch_list>) ROUTE:CHANnel:DRIVE:CLOSE:DEFault? (@<ch_list>) ROUTE:CHANnel:DRIVE:OPEN:DEFault (@<ch_list>) ROUTE:CHANnel:DRIVE:OPEN:DEFault? (@<ch_list>) ROUTE:CHANnel:DRIVE:PAIRed[:MODE] {OFF 0 ON 1}, (@<ch_list>) ROUTE:CHANnel:DRIVE:PAIRed[:MODE]? (@<ch_list>) ROUTE:CHANnel:DRIVE:PULSe[:MODE] {OFF 0 ON 1}, (@<ch_list>) ROUTE:CHANnel:DRIVE:PULSe[:MODE]? (@<ch_list>) ROUTE:CHANnel:DRIVE:PULSe:WIDTh {<seconds> MIN MAX DEF}, (@<ch_list>) ROUTE:CHANnel:DRIVE:PULSe:WIDTh? [{MIN MAX},] (@<ch_list>) ROUTE:CHANnel:DRIVE:STATe? (@<ch_list>) ROUTE:CHANnel:DRIVE:TIME:RECOvery {<seconds> MIN MAX DEF}, (@<ch_list>) ROUTE:CHANnel:DRIVE:TIME:RECOvery? [{MIN MAX},] (@<ch_list>) ROUTE:CHANnel:DRIVE:TIME:SETTle {<seconds> MIN MAX DEF}, (@<ch_list>) ROUTE:CHANnel:DRIVE:TIME:SETTle? [{MIN MAX},] (@<ch_list>) ROUTE:CHANnel:LABel:CLEAR:MODule 1 ROUTE:CHANnel:LABel[:DEFine] "<label>", (@<ch_list>) ROUTE:CHANnel:LABel[:DEFine]? [<type>], (@<ch_list>) ROUTE:CHANnel:VERify[:ENABLE] {OFF 0 ON 1}, (@<ch_list>) ROUTE:CHANnel:VERify[:ENABLE]? (@<ch_list>) ROUTE:CHANnel:VERify:POLarity {NORMal INVerted}, (@<ch_list>) ROUTE:CHANnel:VERify:POLarity? (@<ch_list>) ROUTE:CHANnel:VERify:POSition:STATe? (@<ch_list>) ROUTE:CLOSE (@<ch_list>) ROUTE:CLOSE? (@<ch_list>) ROUTE:MODule:BUSY? {1 ANY} ROUTE:MODule:WAIT 1 ROUTE:MODule:WAIT? 1 ROUTE:OPEN (@<ch_list>) ROUTE:OPEN? (@<ch_list>) ROUTE:OPERation:OVERlap[:ENABLE] {OFF 0 ON 1} ROUTE:OPERation:OVERlap[:ENABLE]?</p>

<p>Switch Control cont'd</p> <p>(Sequence Operation)</p>	<pre> ROUTe:RMODule:Bank:DRive[:MODE] {TTL OCOLlector}, {1-4 BANK1-BANK4 ALL}, (@<rem_ch_list>) ROUTe:RMODule:Bank:DRive[:MODE]? {1-4 BANK1-BANK4}, (@<rem_ch_list>) ROUTe:RMODule:Bank:LED:DRive[:ENABLE] {OFF 0 ON 1}, {1-4 BANK1-BANK4 ALL}, (@<rem_ch_list>) ROUTe:RMODule:Bank:LED:DRive[:ENABLE]? {1-4 BANK1-BANK4}, (@<rem_ch_list>) ROUTe:RMODule:Bank:LED:DRive:LEVel {<amps> MIN MAX DEF}, {1-4 BANK1-BANK4 ALL}, (@<rem_ch_list>) ROUTe:RMODule:Bank:LED:DRive:LEVel? {1-4 BANK1-BANK4}, (@<rem_ch_list>) ROUTe:RMODule:Bank:PRESet {1-4 BANK1-BANK4 ALL}, (@<rem_ch_list>) ROUTe:RMODule:DRive:LIMit {<max_drives> MIN MAX DEF}, (@<rem_ch_list>) ROUTe:RMODule:DRive:LIMit? [{MIN MAX},] (@<rem_ch_list>) ROUTe:RMODule:DRive:SOURce:BOOT {OFF INTERNAL EXTeRnal}, (@<rem_ch_list>) ROUTe:RMODule:DRive:SOURce:BOOT? (@<rem_ch_list>) ROUTe:RMODule:DRive:SOURce[:IMMediate] {OFF INTERNAL EXTeRnal}, (@<rem_ch_list>) ROUTe:RMODule:DRive:SOURce[:IMMediate]? (@<rem_ch_list>) ROUTe:SEquence:ABORt ROUTe:SEquence:BUSY? ROUTe:SEquence:CATalog? ROUTe:SEquence:DEFine <name>, "<commands>" ROUTe:SEquence:DEFine? <name> ROUTe:SEquence:DELeTe:ALL ROUTe:SEquence:DELeTe[:NAME] <name> ROUTe:SEquence:RUNNing:NAME? ROUTe:SEquence:TRIGger[:IMMediate] <name> ROUTe:SEquence:TRIGger:SOURce <name>, MANual ROUTe:SEquence:TRIGger:SOURce? <name> ROUTe:SEquence:WAIT </pre>
<p>DIAGnostic</p>	<pre> DIAGnostic:RELAy:CYCLes? (@<ch_list>) DIAGnostic:RELAy:CYCLes:CLEar (@<ch_list>) </pre>
<p>Status</p>	<pre> *CLS *ESE <enable_value> *ESE? *ESR? *SRE <enable_value> *SRE? *STB? STATus:MODule:ENABle <enable_value> STATus:MODule:ENABle? STATus:MODule:EVENT? STATus:MODule:SLOT1:CONDition? STATus:MODule:SLOT1:ENABle <enable_value> STATus:MODule:SLOT1:ENABle? STATus:MODule:SLOT1:EVENT? </pre>

<p>Status (cont'd)</p>	<p>STATus:OPERation:CONDition? STATus:OPERation:ENABle <enable_value> STATus:OPERation:ENABle? STATus:OPERation[:EVENT]? STATus:PRESet STATus:QUEStionable:CONDition? STATus:QUEStionable:ENABle <enable_value> STATus:QUEStionable:ENABle? STATus:QUEStionable[:EVENT]? SYSTem:MODule?</p>
<p>State Storage</p>	<p>*RCL {1 2 3 4 5} *SAV {1 2 3 4 5} MEMory:NSTates? MEMory:STATe:CATalog? MEMory:STATe:DELete {1 2 3 4 5} MEMory:STATe:DELete:ALL MEMory:STATe:NAME {1 2 3 4 5} [,<name>] MEMory:STATe:NAME? {1 2 3 4 5} MEMory:STATe:RECall:AUTO {OFF 0 ON 1} MEMory:STATe:RECall:AUTO? MEMory:STATe:RECall:SElect {1 2 3 4 5} MEMory:STATe:RECall:SElect? MEMory:STATe:VALid? {1 2 3 4 5}</p>
<p>IEEE-488 Com- mands</p>	<p>*CLS *ESE <enable_value> *ESE? *ESR? *IDN? *OPC *OPC? *RCL {1 2 3 4 5} *RST *SAV {1 2 3 4 5} *SRE <enable_value> *SRE? *STB? *TRG *TST? *WAI</p>
<p>System - Related Commands</p>	<p>SYSTem:CDEscription? 1 SYSTem:COMMunicate:ENABle {OFF 0 ON 1},{GPIB LAN SOCKets TEL- Net VXI11 WEB} SYSTem:COMMunicate:ENABle? {GPIB LAN SOCKets TELNet VXI11 WEB} SYSTem:COMMunicate:GPIB:ADDRess <address> SYSTem:COMMunicate:GPIB:ADDRess? SYSTem:COMMunicate:GPIB:ADDRess:INSTalled? SYSTem:CPON 1 SYSTem:CTYPE? 1 SYSTem:CTYPE:RModule? (@<rem_ch>) [,<dist_board>] SYSTem:DATE <yyyy>,<mm>,<dd> SYSTem:DATE? SYSTem:DELay[:IMMediate] <seconds> SYSTem:ERRor?</p>

<p>System - Related Commands (cont'd)</p>	<p>SYSTem:LOCK:OWNer? SYSTem:LOCK:RELease SYSTem:LOCK:REQuest? SYSTem:MODule? SYSTem:PRESet SYSTem:RMODule:RESet 1 SYSTem:RMODule:STATus? 1 SYSTem:SECurity:IMMediate SYSTem:TIME <hh>,<mm>,<ss.sss> SYSTem:TIME? SYSTem:VERSiOn?</p>
<p>LAN Configuration Commands</p>	<p>SYSTem:COMMunicate:LAN:AUTOip {OFF 0 ON 1} SYSTem:COMMunicate:LAN:AUTOip? SYSTem:COMMunicate:LAN:BSTatus? SYSTem:COMMunicate:LAN:CONTRol? SYSTem:COMMunicate:LAN:DHCP {OFF 0 ON 1} SYSTem:COMMunicate:LAN:DHCP? SYSTem:COMMunicate:LAN:DNS "<address>" SYSTem:COMMunicate:LAN:DNS? SYSTem:COMMunicate:LAN:DOMain "<name>" SYSTem:COMMunicate:LAN:DOMain? [{CURRENT STATIC}] SYSTem:COMMunicate:LAN:GATEway <address> SYSTem:COMMunicate:LAN:GATEway? [{CURRENT STATIC}] SYSTem:COMMunicate:LAN:HISTory:CLEar SYSTem:COMMunicate:LAN:HISTory? SYSTem:COMMunicate:LAN:HOSTname "<name>" SYSTem:COMMunicate:LAN:HOSTname? [{CURRENT STATIC}] SYSTem:COMMunicate:LAN:IPADdress "<address>" SYSTem:COMMunicate:LAN:IPADdress? [{CURRENT STATIC}] SYSTem:COMMunicate:LAN:KEEPalive {<seconds> MIN MAX} SYSTem:COMMunicate:LAN:KEEPalive? [{MIN MAX}] SYSTem:COMMunicate:LAN:MAC? SYSTem:COMMunicate:LAN:SMASK "<mask>" SYSTem:COMMunicate:LAN:SMASK? [{CURRENT STATIC}] SYSTem:COMMunicate:LAN:TELNet:PROMpt "<string>" SYSTem:COMMunicate:LAN:TELNet:PROMpt? SYSTem:COMMunicate:LAN:TELNet:WMEssage "<string>" SYSTem:COMMunicate:LAN:TELNet:WMEssage?</p>
<p>L4490A/L4491A Option 004 Commands</p>	<p>CONFigure:DiGital <width>, [<voltage>,<polarity>] (@<ch_list>) CONFigure:DiGital:DiRection <direction>, (@<ch_list>) CONFigure:DiGital:DiRection? (@<ch_list>) CONFigure? [(@<ch_list>)] MEASure:DiGital? <width>, [<voltage>,<polarity>] (@<ch_list>) [SENSe:]DiGital:DATA:BIT? <bit>, (@<ch_list>) [SENSe:]DiGital:DATA[:<width>]? [<format>] (@<ch_list>) SOURce:DiGital:DATA:BIT {0 1}, <bit>, (@<ch_list>) SOURce:DiGital:DATA:BIT? <bit>, (@<ch_list>) SOURce:DiGital:STATe <mode>, (@<ch_list>) SOURce:DiGital:STATe? (@<ch_list>)</p>

Y1150A - Y1155A Switch Control Tables

The following tables relate switch control actions ‘open’ and ‘close’ to the state of the switch and attenuator. The tables are identified by distribution board.

Y1150A Switch Control

The switch control for the Y1150A distribution board is shown below. All channels are driven in the PAIRed mode (**Preset** state). See Figure 4-10 for additional information. See Chapter 2 for bank-specific channel numbering.

Channel / Switch	Switch State	
	State A	State B
Channel 1xx1 / SW1	ROUT:OPEN (@1xx1)	ROUT:CLOS (@1xx1)
Channel 1xx2 / SW2	ROUT:OPEN (@1xx2)	ROUT:CLOS (@1xx2)
Channel 1xx3 / SW3	ROUT:OPEN (@1xx3)	ROUT:CLOS (@1xx3)
Channel 1xx4 / SW4	ROUT:OPEN (@1xx4)	ROUT:CLOS (@1xx4)
Channel 1xx5 / SW5	ROUT:OPEN (@1xx5)	ROUT:CLOS (@1xx5)
Channel 1xx6 / SW6	ROUT:OPEN (@1xx6)	ROUT:CLOS (@1xx6)
Channel 1xx7 / SW7	ROUT:OPEN (@1xx7)	ROUT:CLOS (@1xx7)
Channel 1xx8 / SW8	ROUT:OPEN (@1xx8)	ROUT:CLOS (@1xx8)

Y1151A Switch Control

The switch control for the Y1151A distribution board is shown below. All channels are driven in the single (un-paired) mode (**Preset** state). See Figure 4-11 for additional information. See Chapter 2 for specific channel numbering.

Channel / Switch 1	Path Closed	Path Open
Channel 1xx1 / SW1 Path 1	ROUT:CLOS (@1xx1)	Close another path or open all
Channel 1xx2 / SW1 Path 2	ROUT:CLOS (@1xx2)	Close another path or open all
Channel 1xx3 / SW1 Path 3	ROUT:CLOS (@1xx3)	Close another path or open all
Channel 1xx4 / SW1 Path 4	ROUT:CLOS (@1xx4)	Close another path or open all
Channel 1xx5 / SW1 Path 5	ROUT:CLOS (@1xx5)	Close another path or open all
Channel 1xx6 / SW1 Path 6	ROUT:CLOS (@1xx6)	Close another path or open all
Channel 1xx7 / SW1 Open All 1	ROUT:CLOS (@1xx7)	note: use either channel to open all
Channel 1xx8 / SW1 Open All 2	ROUT:CLOS (@1xx8)	

Channel / Switch 2	Path Closed	Path Open
Channel 1xx1 / SW2 Path 1	ROUT:CLOS (@1xx1)	Close another path or open all
Channel 1xx2 /SW2 Path 2	ROUT:CLOS (@1xx2)	Close another path or open all
Channel 1xx3 /SW2 Path 3	ROUT:CLOS (@1xx3)	Close another path or open all
Channel 1xx4 /SW2 Path 4	ROUT:CLOS (@1xx4)	Close another path or open all
Channel 1xx5 /SW2 Path 5	ROUT:CLOS (@1xx5)	Close another path or open all
Channel 1xx6 /SW2 Path 6	ROUT:CLOS (@1xx6)	Close another path or open all
Channel 1xx7 /SW2 Open All 1	ROUT:CLOS (@1xx7)	note: use either channel to open all
Channel 1xx8 /SW2 Open All 2	ROUT:CLOS (@1xx8)	

Y1152A Switch Control

The switch control for the Y1152A distribution board is shown below. All channels are driven in the PAIRed mode (**Preset** state). See Figure 4- 12 for additional information. See Chapter 2 for bank-specific channel numbering.

* Note that for switches connected to SW1, path closed is accomplished with the ROUTE:OPEN command and path opened is accomplished through the ROUTE:CLOSE command.

Channel / Switch	Path State	
	Path Closed*	Path Opened*
Channel 1xx1 /SW1 Path1	ROUT:OPEN (@1xx1)	ROUT:CLOS (@1xx1)
Channel 1xx2 /SW1 Path2	ROUT:OPEN (@1xx2)	ROUT:CLOS (@1xx2)
Channel 1xx3 /SW1 Path3	ROUT:OPEN (@1xx3)	ROUT:CLOS (@1xx3)
Channel 1xx4 /SW1 Path4	ROUT:OPEN (@1xx4)	ROUT:CLOS (@1xx4)
Channel 1xx5 /SW1 Path5	ROUT:OPEN (@1xx5)	ROUT:CLOS (@1xx5)
Channel 1xx6 /SW1 Path6	ROUT:OPEN (@1xx6)	ROUT:CLOS (@1xx6)
Channel / Switch	Switch State	
	State A	State B
Channel 1xx7 /SW2	ROUT:OPEN (@1xx7)	ROUT:CLOS (@1xx7)
Channel 1xx8 /SW3	ROUT:OPEN (@1xx8)	ROUT:CLOS (@1xx8)

Y1153A Switch Control

The switch control for the Y1153A distribution board is shown below. All channels are driven in the PAIRed mode (Preset state). See Figure 4-13 for additional information. See Chapter 2 for bank-specific channel numbering.

ROUTe:OPEN adds that section's attenuation amount to the overall attenuation. Total attenuation is the sum of the dB amounts for the individual sections switched in. When all channels open at reset maximum attenuation is set.

Channel / Attenuator Section	Attenuation State	
	Attenuation Section In	Attenuation Section Out
Channel 1xx1 / ATTN 1 SEC 1	ROUT:OPEN (@1xx1)	ROUT:CLOS (@1xx1)
Channel 1xx2 / ATTN 1 SEC 2	ROUT:OPEN (@1xx2)	ROUT:CLOS (@1xx2)
Channel 1xx3 / ATTN 1 SEC 3	ROUT:OPEN (@1xx3)	ROUT:CLOS (@1xx3)
Channel 1xx4 / ATTN 1 SEC 4	ROUT:OPEN (@1xx4)	ROUT:CLOS (@1xx4)
Channel 1xx5 / ATTN 2 SEC 1	ROUT:OPEN (@1xx5)	ROUT:CLOS (@1xx5)
Channel 1xx6 / ATTN 2 SEC 2	ROUT:OPEN (@1xx6)	ROUT:CLOS (@1xx6)
Channel 1xx7 / ATTN 2 SEC 3	ROUT:OPEN (@1xx7)	ROUT:CLOS (@1xx7)
Channel 1xx8 / ATTN 2 SEC 4	ROUT:OPEN (@1xx8)	ROUT:CLOS (@1xx8)

Y1154A Switch Control

The switch control for the Y1154A distribution board is shown below. All channels are driven in the PAIRed mode (Preset state). See Figure 4-14 for additional information. See Chapter 2 for bank-specific channel numbering.

Channel / Switch	Switch State	
	State A	State B
Channel 1xx1 / SW1	ROUT:OPEN (@1xx1)	ROUT:CLOS (@1xx1)
Channel 1xx2 / SW2	ROUT:OPEN (@1xx2)	ROUT:CLOS (@1xx2)
Channel 1xx3 / SW3	ROUT:OPEN (@1xx3)	ROUT:CLOS (@1xx3)
Channel 1xx4 / SW4	ROUT:OPEN (@1xx4)	ROUT:CLOS (@1xx4)
Channel 1xx5 / SW5	ROUT:OPEN (@1xx5)	ROUT:CLOS (@1xx5)
Channel 1xx6 / SW6	ROUT:OPEN (@1xx6)	ROUT:CLOS (@1xx6)
Channel 1xx7 / SW7	ROUT:OPEN (@1xx7)	ROUT:CLOS (@1xx7)
Channel 1xx8 / SW8	ROUT:OPEN (@1xx8)	ROUT:CLOS (@1xx8)

Y1155A Switch Control

The switch control for the Y1155A distribution board is shown below. Channels may be driven in single (un-paired) mode (**Preset** state), or in PAIRed mode. See Figure 4-15 for additional information. See Chapter 2 for bank-specific channel numbering.

Single (un-paired) Mode

Channel 1xx1 / Screw Term 1	ROUT:CLOS (@1xx1)
Channel 1xx2 / Screw Term 2	ROUT:CLOS (@1xx2)
Channel 1xx3 / Screw Term 3	ROUT:CLOS (@1xx3)
Channel 1xx4 / Screw Term 4	ROUT:CLOS (@1xx4)
Channel 1xx5 / Screw Term 5	ROUT:CLOS (@1xx5)
Channel 1xx6 / Screw Term 6	ROUT:CLOS (@1xx6)
Channel 1xx7 / Screw Term 7	ROUT:CLOS (@1xx7)
Channel 1xx8 / Screw Term 8	ROUT:CLOS (@1xx8)
Channel 1xx1 / Screw Term 11	ROUT:CLOS (@1xx1)
Channel 1xx2 / Screw Term 12	ROUT:CLOS (@1xx2)
Channel 1xx3 / Screw Term 13	ROUT:CLOS (@1xx3)
Channel 1xx4 / Screw Term 14	ROUT:CLOS (@1xx4)
Channel 1xx5 / Screw Term 15	ROUT:CLOS (@1xx5)
Channel 1xx6 / Screw Term 16	ROUT:CLOS (@1xx6)
Channel 1xx7 / Screw Term 17	ROUT:CLOS (@1xx7)
Channel 1xx8 / Screw Term 18	ROUT:CLOS (@1xx8)

Paired Mode

Channel 1xx1 / Screw Term 1	ROUT:OPEN (@1xx1)	ROUT:CLOS (@1xx1)
Channel 1xx2 / Screw Term 2	ROUT:OPEN (@1xx2)	ROUT:CLOS (@1xx2)
Channel 1xx3 / Screw Term 3	ROUT:OPEN (@1xx3)	ROUT:CLOS (@1xx3)
Channel 1xx4 / Screw Term 4	ROUT:OPEN (@1xx4)	ROUT:CLOS (@1xx4)
Channel 1xx5 / Screw Term 5	ROUT:OPEN (@1xx5)	ROUT:CLOS (@1xx5)
Channel 1xx6 / Screw Term 6	ROUT:OPEN (@1xx6)	ROUT:CLOS (@1xx6)
Channel 1xx7 / Screw Term 7	ROUT:OPEN (@1xx7)	ROUT:CLOS (@1xx7)
Channel 1xx8 / Screw Term 8	ROUT:OPEN (@1xx8)	ROUT:CLOS (@1xx8)

Y1155A LED Connector Pins

Pin definitions for the Y1155A distribution board LED connectors are determined by the un-paired or paired mode of the Y1155A channels. The pin definitions for both modes are shown below.

Un-paired Mode

LED1 Connector				LED2 Connector			
Pin	Use	Pin	Use	Pin	Use	Pin	Use
1	+VI	2	SW1	1	+VI	2	SW11
3	+VI	4	SW2	3	+VI	4	SW12
5	+VI	6	SW3	5	+VI	6	SW13
7	+VI	8	SW4	7	+VI	8	SW14
9	+VI	10	SW5	9	+VI	10	SW15
11	+VI	12	SW6	11	+VI	12	SW16
13	+VI	14	SW7	13	+VI	14	SW17
15	+VI	16	SW8	15	+VI	16	SW18

Paired Mode

LED1 Connector				LED2 Connector			
Pin	Use	Pin	Use	Pin	Use	Pin	Use
1	+VI	2	SW1 - A	1	+VI	2	SW1 - B
3	+VI	4	SW2 - A	3	+VI	4	SW2 - B
5	+VI	6	SW3 - A	5	+VI	6	SW3 - B
7	+VI	8	SW4 - A	7	+VI	8	SW4 - B
9	+VI	10	SW5 - A	9	+VI	10	SW5 - B
11	+VI	12	SW6 - A	11	+VI	12	SW6 - B
13	+VI	14	SW7 - A	13	+VI	14	SW7 - B
15	+VI	16	SW8 - A	15	+VI	16	SW8 - B

Drive Modes

The 34945EXT module within the L4490A/L4491A RF Switch Platform can drive switches and attenuators using either TTL or open collector drive methods. The TTL drive mode uses active drive for both high and low levels and drives a TTL high level when asserted. The open collector drive provides a current path to ground when asserted.

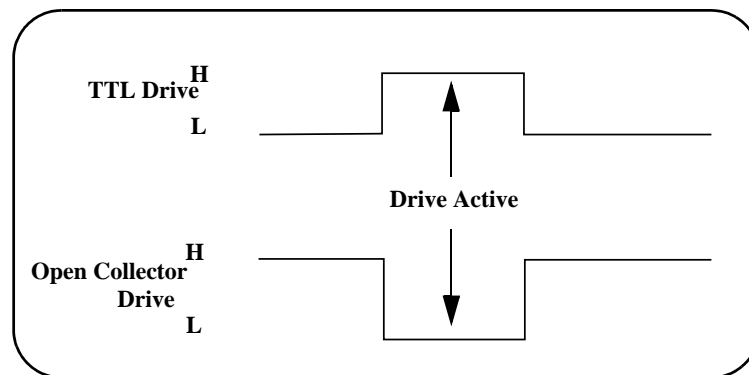

Figure 5-1. TTL and Open Collector Drive Modes.

The drive mode is set on a per bank basis and is included in the distribution board's preset configuration. The drive mode can be changed using the command:

```
ROUTE:RModule: BANK:DRIVE:MODE
```

Using Single-Coil Switches and Attenuators

Some microwave switches require a single drive (coil). With single coil devices, note that the channel numbering is not consecutive across all channels in a bank (see Chapter 2 “Channel Numbering”).

The L4490A/L4491A can provide single coil devices with either pulsed or continuous drive current. Settings and parameters for continuous drive mode are given in the next section.

Continuous Drive Mode

Driving non-latching devices requires a power supply capable of handling sustained high current requirements. You may only use continuous drive current with channels configured for single drive. Additionally, to prevent an overcurrent condition within the power supply, care must be taken when operating more than one continuous drive at a time. The drive type may be configured as either TTL or open-collector.

Using Continuous Drive

Figure 5-2 illustrates the continuous drive signals for two channels (switches) and the relationship of the drive parameters to the power supply requirements.

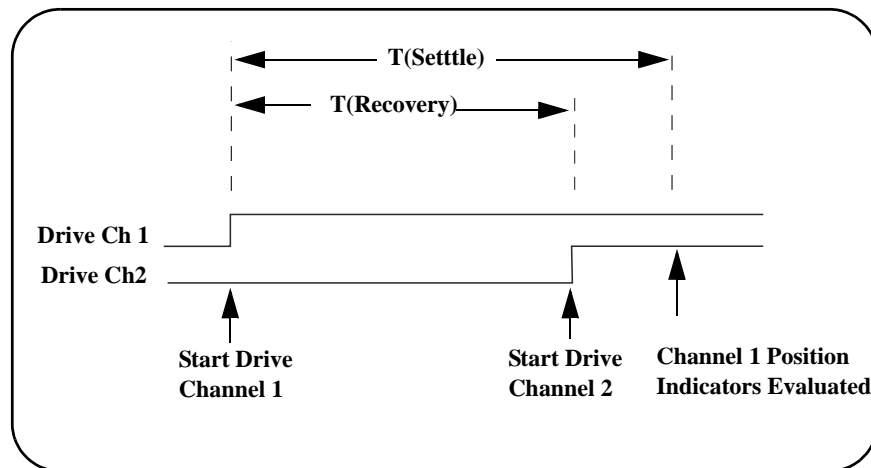

Figure 5-2. Continuous Drive Signals.

As shown in the figure, the drive signal is initially applied to channel 1. Drive is applied to channel 2 only after a power supply recovery period has elapsed $T(\text{Recovery})$.

The power supply recovery time can be set for each channel, and is set to 0.0 ms during a bank **preset** (Chapter 4). The recovery time can be changed using the command:

```
ROUTE:CHANnel:DRIVE:TIME:RECOvery
```

When verifying channel closure, you can also specify a settling time (T(Settle)). This parameter ensures the switch has had time to change state before the position indicator (of the switch) is evaluated.

The settling time can be set for each channel and is set to 0.0 ms during a bank **preset** (Chapter 4). The settling time can be changed using the command

```
ROUTE:CHANnel:DRIVE:TIME:SETTle
```

Single Coil with Separate Position Indicators Connection Diagram

The simplified schematic on the following page illustrates the connection for a single coil switch (e.g. 8710x, 8740x) with separate position indicators. The position indicators for this type of switch are independent relay contacts that are mechanically linked to the RF switch position.

Even though this is a single coil (drive) switch, each switch state has its own coil. The switch uses internal logic to open all paths except the one being closed.

The RF paths are not shown in the simplified diagram. The coils are driven in open collector mode. The position indicator is set so that a high level indicates an active switch. The logic level of the position indicator can be inverted using the `ROUTE:CHANnel:VERify:POLarity` command.

The schematic shown is similar to the Agilent 87104A/B/C, 87106A/B/C, and 87406B switches. Many other switches use this technique (both with and without the position indicator) but may not have the logic described.

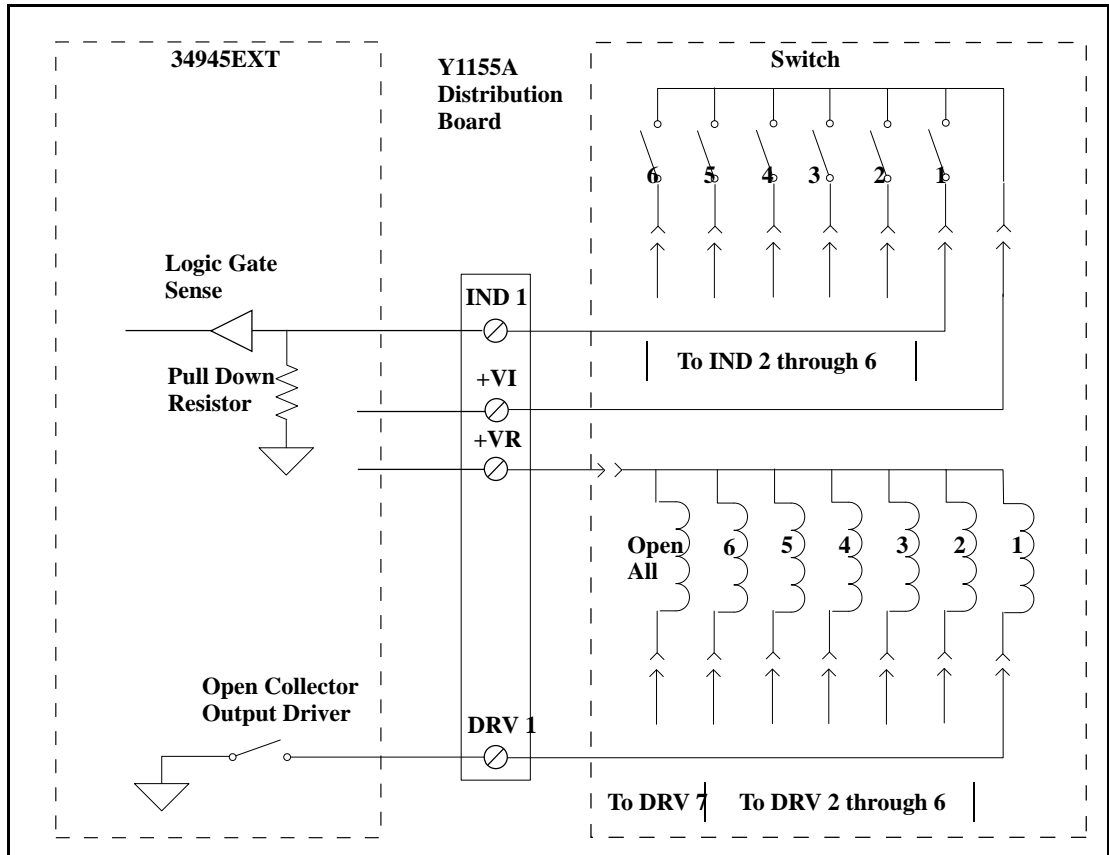

Figure 5-3. Single-Coil Switch Connection Diagram (separate position indicators).

Using Dual-Coil Switches and Attenuators

Many microwave switches and attenuators have a paired drive input. Typically, one drive is electrically connected to the lower channel number in a bank and one connected to a corresponding upper channel number. For example, on bank 2 a dual drive switch should have its 'State A' coil connected to channel 21 and its 'State B' coil connected to channel 31.

The L4490A/L4491A drives dual coil devices in pulsed mode only (ROUTE:CHANnel:DRIVE:PULSe:MODE ON). Pairing two channels (ROUTE:CHANnel:DRIVE:PAIR:MODE ON) automatically configures the channels to pulsed mode. You must turn the paired mode 'off' before continuous drive mode can be enabled).

Based on the distribution board installed, **presetting** the bank will either enable paired mode (ON) or disable paired mode (OFF) according to the type of switches supported by the board.

Pairing Channels

With dual-coil devices, the channels in the bank are paired during a bank **preset**. Pairing channels allows settings and control to be shared between the two channels. When paired, channels 1-8 are paired with 11-18 (bank 1), 21-28 with 31-38 (bank 2), 41-48 with 51-58 (bank 3), and 61-68 with 71-78 (bank 4). For example, a **preset** of bank 1 (Chapter 4) with an applicable distribution board or sending the command:

```
ROUTe:CHANnel:DRIVE:PAIRed:MODE ON, (@1101)
```

pairs channel 1 and channel 11. A bank preset pairs all channels in a bank as would the command sent to bank 1:

```
ROUTe:CHANnel:DRIVE:PAIRed:MODE ON, (@1101:1108)
```

As mentioned in Chapter 2, paired channels are controlled by a single command and only the lower channel of the pair is specified. Thus, the settings provided by the following commands:

```
ROUTe:CHANnel:DRIVE:PULSe:WIDTh
```

```
ROUTe:CHANnel:DRIVE:TIme:RECOvery
```

```
ROUTe:CHANnel:DRIVE:TIme:SETTle
```

```
ROUTe:CHANnel:VERify:ENABle
```

apply to both channels in the pair.

Paired Drive With Separate Position Indicators

The simplified schematic below illustrates the connection for a dual coil switch with separate position indicators. The position indicators for this type of switch are independent relay contacts that are mechanically linked to the RF switch position.

The RF paths are not shown in the simplified diagram. The coils are driven in open collector mode. The position indicator is set so that a high level indicates an active switch. The logic level of the position indicator can be inverted using the `ROUTe:CHANnel:VERify:POLarity` command.

As shown, Channel 01 was pulsed to close Coil A. The corresponding position indicator also closed. Closing position indicator A opens position indicator B.

The schematic shown is similar to the Agilent N181x series of switches.

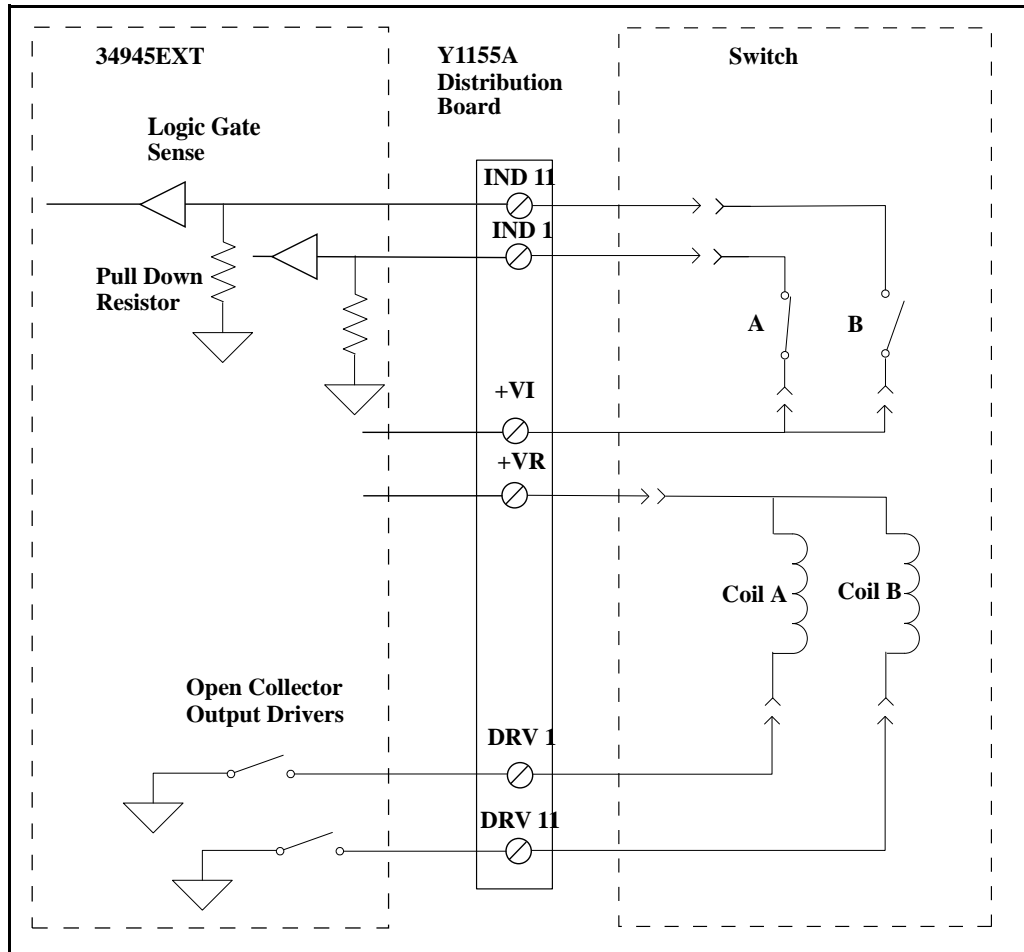

Figure 5-4. Dual-Coil Switch Connection Diagram (separate position indicators).

Paired Drive With Combined Position Indicators

The simplified schematic below illustrates the connection for a dual drive switch with an integral position indicator. The position indicators for this type of switch are electrically connected to the device's drive coil. This is a typical arrangement for microwave attenuators. For these types of position indicators, you must make a parallel connection at the distribution board between the channel drive and the indicator input.

With these types of devices, positive voltage is present on the paired coil opposite the position the switch is currently in. Typically you will need to invert the logic level of the position indicator using the `ROUTE:CHANNEL:VERIFY:POLarity` command.

As shown, Channel 01 was pulsed to close Port 1. The corresponding position indicator also closed.

The schematic shown is similar to the Agilent 876x series of switches and 849x series of step attenuators.

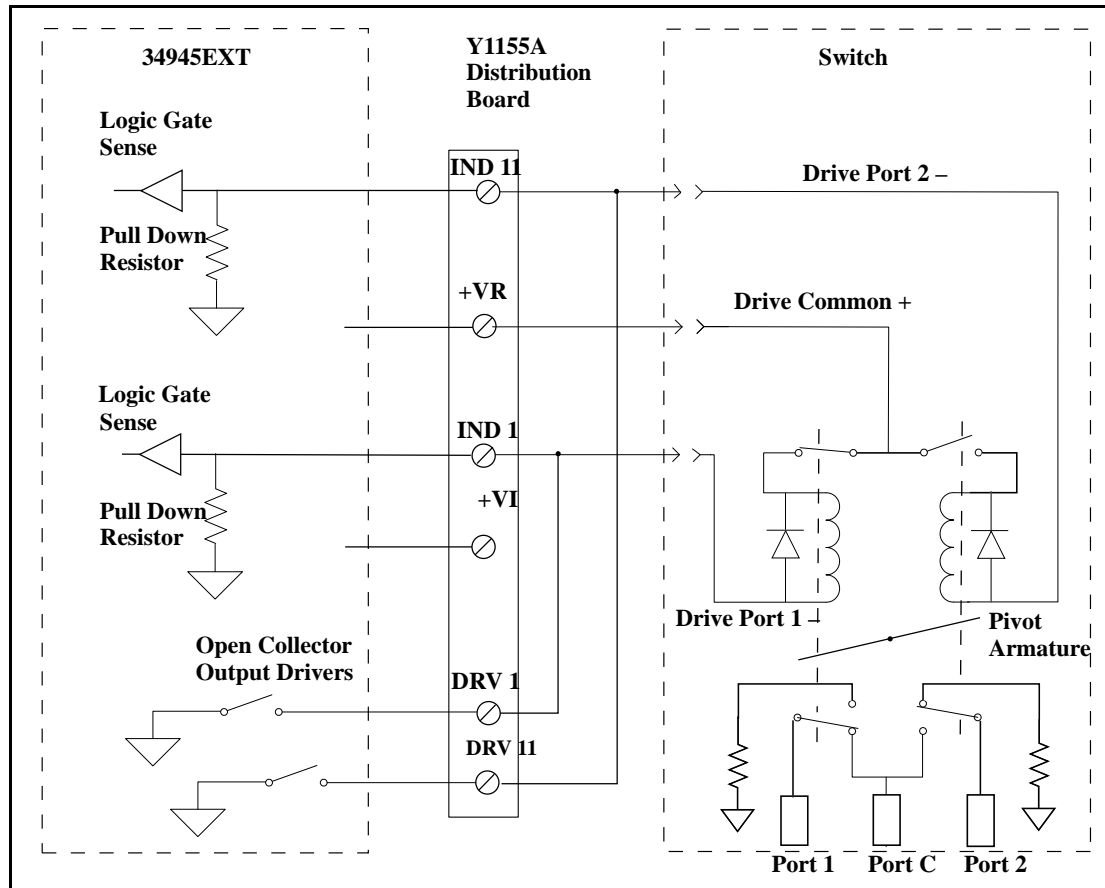

Figure 5-5. Dual-Coil Switch Connection Diagram (combined position indicators).

Pulsed Actuation Mode

The pulsed actuation mode is set during a bank **preset**. Pulsed mode can also be set with the command:

```
ROUTE:CHANnel:DRIVE:PULSe:MODE ON
```

It is also set when channels are paired either through a bank **preset** or with the command:

```
ROUTE:CHANnel:DRIVE:PAIRed:MODE ON
```

Figure 5-6 illustrates the pulse actuation for two channels (switches) and the relationship of the drive parameters to the power supply requirements.

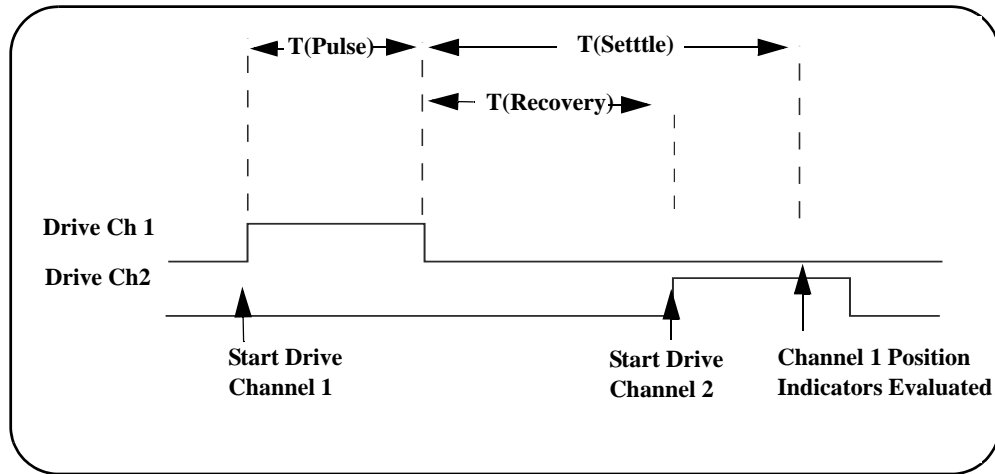

Figure 5-6. Pulse Actuation Mode Diagram.

As shown in the figure, the actuation pulse is applied to channel 1 and held for the $T(\text{Pulse})$ time set by the bank **preset** which is 15.0 ms, or as set with the command:

```
ROUTE:CHANnel:DRIVE:PULSe:WIDTh
```

The actuation pulse is applied to channel 2 only after a power supply recovery period has elapsed $T(\text{Recovery})$. The power supply recovery time can be set for each channel, and is set to 0.0 ms during a bank **preset** (Chapter 4). The recovery time can be changed using the command:

```
ROUTE:CHANnel:DRIVE:TIME:RECOvery
```

When verifying channel closure, you can also specify a settling time ($T(\text{Settle})$). This parameter ensures the switch has had time to change state before the position indicator (of the switch) is evaluated.

The settling time can be set for each channel and is set to 0.0 ms during a bank **preset** (Chapter 4). The settling time can be changed using the command

```
ROUTE:CHANnel:DRIVE:TIME:SETTle
```

The L4490A/L4491A will always pulse a channel in response to a `ROUTE:OPEN` or `ROUTE:CLOSE` command. For example, sending `ROUTE:CLOSE` to a channel three times in a row will result in three actuation pulses.

NOTE

A single coil (unpaired) channel operating in pulsed mode with channel verification turned off (default) will report the channel as 'stateless' and return an error if the command:

```
ROUTE:CLOSE?
```

is sent. Single coil channels driven by an actuation pulse must have verification enabled with the command:

```
ROUTE:CHANNEL:VERIFY ON)
```

to query the channel state using the ROUTE:CLOSE? query.

Overcurrent Conditions

During operation, exceeding the L4490A/L4491A internal switch drive power supply current specification of 600 mA can cause overcurrent conditions within the instrument's power supply, thus shutting down the supply and generating errors such as:

```
+943,"Remote module topology change; Slot 1: Slot must be reset"
```

```
+308,"Channel not able to perform requested operation; Chan 1101: Remote module channel drive disabled"
```

```
+935,"Overcurrent detected"
```

In this situation, the overcurrent condition must be removed and you must cycle power on the L4490A/L4491A to re-enable the supply.

Overcurrent conditions are often caused by the actuation (switching) current the switch requires, and the duty cycle of the actuation pulse.

For the L4490A/L4491A, the duty cycle is set through **presets** of the distribution boards, or can be set programmatically by combination of the commands:

```
ROUT:CHANNEL:DRIVE:PULSE:Width
```

```
ROUTE:CHANNEL:DRIVE:TIME:RECOVERY
```

Figure 5-7 shows the relationship between actuation pulse width and power supply recovery time.

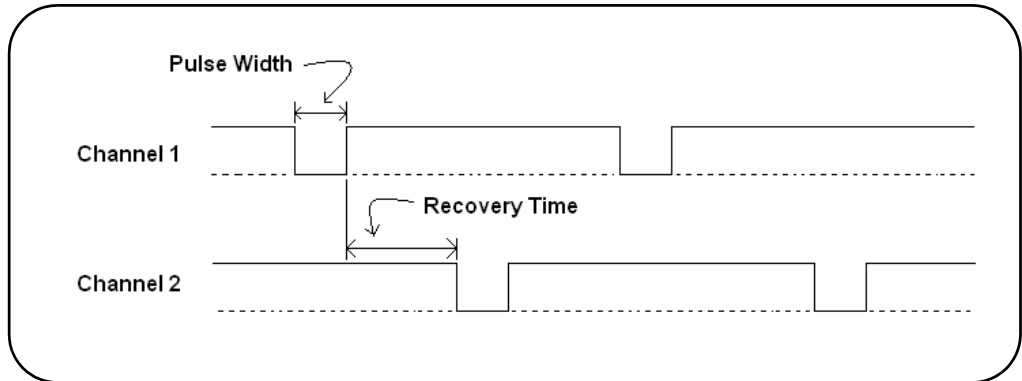

Figure 5-7. Actuation Pulse Duty Cycle: Pulse Width + Recovery Time.

Overcurrent conditions can often be avoided with an activation pulse duty cycle of 25%. This allows the power supply to recover before the next actuation pulse is sent. An example of pulse width and recovery time values that achieve a 25% duty cycle is:

```
ROUT:CHANnel:DRIVE:PULSe:Width 0.015, (@1101)
```

```
ROUTE:CHANnel:DRIVE:TIME:RECOvery 0.045, (@1101)
```

Because switching speeds vary between switches, it may be necessary to vary the pulse width and recovery time settings to achieve values that prevent overcurrent conditions, yet still achieve the desired system performance. Using switches with current interrupt options can also increase performance as less power is consumed by the switch.

Overcurrent Conditions with External Supplies

Overcurrent conditions can occur using an external supply if the supported 2A limit of the 34945EXT is momentarily exceeded. The duty cycle of the externally supplied actuation pulse is regulated using the same commands as used with the internal supply.

Command Execution Times

Setting pulse widths and/or power supply recovery times at, or close to their maximum values results in longer command (open/close) execution times. For example, setting a channel pulse width of 255 ms and a recovery time of 255 ms requires 510 ms for the command to complete. Setting these values for all channels on the 34945EXT could result in an execution time of over 30 seconds.

Note that during a reset, all channel states are actuated resulting in possible delays during the execution of:

```
*RST
SYSTem:CPON
ROUte:RMOdule:DRIVe:SOURce
```

Verifying Switch States

Many switches and attenuators have built-in switch position indicators. The indicators can be used to drive LED position indicators on the distribution boards. The L4490A/L4491A checks the switch position indicator against the SCPI command last sent to provide verification of the state.

Enabling Verification

Following a preset of any of the distribution boards, electronic verification is disabled and the switch state is assumed to be the last open/close state driven. Verification is enabled through the channel configuration window (Chapter 4) or using the command:

```
ROUte:CHANnel:VERify:ENABle
```

If a switch operation appears to have failed while electronic verification is enabled, an error is generated at the time either of the commands:

```
ROUte:CLOSe
```

```
ROUte:OPEN
```

is executed. If either of these commands specify a channel list (i.e., more than one channel), the verification is performed after all open/close operations have completed. An error is generated for each channel operation that did not verify correctly.

With electronic verification enabled, the commands:

```
ROUte:CLOSe?
```

```
ROUte:OPEN?
```

return the actual (verified) hardware state of the specified channel(s), which may or may not correspond to the programmed state.

Electronic verification of switch position will slow performance of the verified channels. Additionally, if you have enabled the command overlap function using the command:

```
ROUte:OPERation:OVERlap:ENABle ON
```

any overlapping is suspended until position verification is complete.

Verification Line Polarity

The polarity of the verification lines is set following a **preset** of the distribution boards for the switches it supports. The polarity can also be set from the channel configuration window (Chapter 4) or with the command:

```
ROUTE:CHANNEL:VERIFY:POLARITY
```

The polarity settings are `NORMAL` (active high - closed) or `INVERTED` (active low - closed).

Verifying the Switch State Independently

Electronic verification of the switch position is also possible without enabling verification from the channel configuration window (Chapter 4) or through the `ROUTE:CHANNEL:VERIFY:ENABLE` command. The command:

```
ROUTE:CHANNEL:VERIFY:POSITION:STATE?
```

verifies the channel state electronically and is useful when verification is disabled for performance reasons.

Switch States Using Paired Channels

For paired channels, enabling electronic verification on the lower paired channel also enables verification of the higher channel. The verification checks for complementary switch positions of the lower and upper channels (i.e., the position indicators should indicate opposite states). If the position indicators are found to be in the same state an error is generated and the state of the lower channel is assumed.

When the paired mode is disabled and pulsed mode is enabled, you cannot query the channel state (opened/closed) unless verification is enabled. Also, with this configuration, only “close” operations are allowed.

LED Drive Indicators

The distribution boards contain a ribbon cable header that can be used to connect LEDs to provide a visual indication of switch state (Chapter 2). These lines reflect the state of their corresponding channel’s position indicator. Some systems use the LEDs as a graphical indicator of switch positions.

The LED drive indicators are enabled following a **preset** of the distribution boards (Chapter 4) and are also enabled with the command:

```
ROUTE:RMODULE:BANK:LED:DRIVE:ENABLE
```

The drive current for the LEDs can be set from the bank configuration window (Chapter 4) or with the command:

```
ROUTE:RMODULE:BANK:LED:DRIVE:LEVEL
```

You do not need to provide an external current limiting resistor.

NOTE

The LEDs obtain their power from the power supply of the 34945EXT module. If command:

```
ROUTE:RModule:DRIVE:SOURCE OFF
```

has been sent, the LEDs will not operate. Refer to Chapter 2 for additional information on LED connector pin definitions and cabling.

L4490A/L4491A Digital IO and Relay Driver Option 004

The following sections contain additional information on the digital (general purpose) IO and relay drive option to the RF switch platform.

Digital I/O Functions

The Digital input/output (DIO) channels (2001, 2002) each provide an 8-bit byte of DIO, which may be accessed separately or combined together to form one 16-bit word. In addition to these 16 bits, the P102 connector contains three output-only control lines (pins 22-24 - Chapter 4) that are always enabled. These lines represent the handshake sequence that regulates read/write data transfers (Figure 5-8).

Data Read Sequence

When reading data on the input as with the command:

```
SENSe:DIGital:DATA[:<width>]? [<format>,] (@<ch_list>)
```

control line 3 (read/write status line - pin 24) is set high. If the read target is byte 1 (channel 2001), control line 1 is set strobe low, the byte 1 data is read, and then control line 1 is set strobe high. The strobe pulse width is 3.75 μs , and the time from strobe low to valid data is 1.25 μs .

Similarly, if the read target is byte 2 (channel 2002), control line 2 is set strobe low, the byte 2 data is read, and then control line 2 is set strobe high. The strobe pulse width is 3.75 μs , and the time from strobe low to valid data is 1.25 μs .

If both bytes (channels 2001 and 2002 combined) are targeted as a word, both control lines 1 and 2 are set strobe low, both bytes (16-bits) are read on the input, and both control lines are set strobe high. The strobe pulse width is longer (5 μs) than for a single byte read, but the time from strobe low to valid data is still 1.25 μs .

In all three instances, once the data has been read, the data lines are left in tri-state (indeterminate).

Data Write Sequence

When writing data to the output as with the command:

```
SOURce:DIGital:DATA[:<width>] <data>, (@<ch_list>)
```

control line 3 (read/write status line - pin 24) is set low. If the write target is byte 1 (channel 2001), control line 1 is set strobe low, the byte 1 data is written to the output, and then control line 1 is set strobe high. Valid data is present 1.25 μ s before the control line strobe is set high. Control line 3 is then set high.

Similarly, if the write target is byte 2 (channel 2002), control line 2 is set strobe low, the byte 2 data is written to the output, and then control line 2 is set strobe high. Valid data is present 1.25 μ s before the control line strobe is set high. Control line 3 is then set high.

If both bytes (channels 2001 and 2002 combined) are targeted in the write, both control lines 1 and 2 are set strobe low, both bytes' data are written to the output (16-bits), and both control lines are set strobe high. Valid data is present 1.25 μ s before the control line strobe is set high. Control line 3 is then set high.

In all three instances, once the data has been written, the data is kept on the data lines until another (read or write) command changes them.

Digital Read and Write Timing Diagrams

The strobe timing, control line status and data timing for the read and write commands as explained above are illustrated in the diagrams that follow:

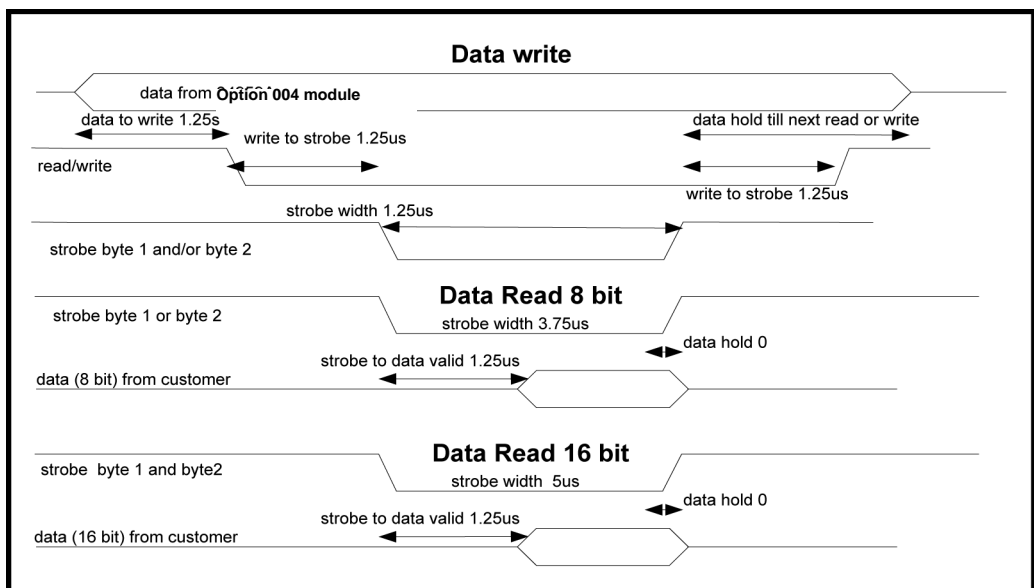
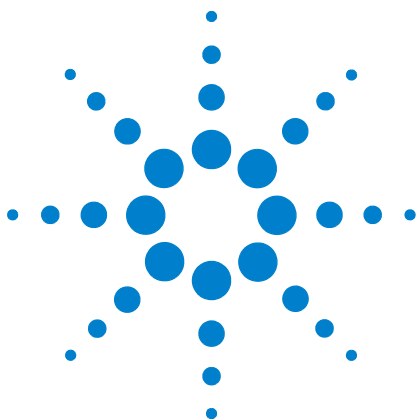

Figure 5-8. Digital IO Read and Write Timing Diagrams.



A Y1157A - Y1159A Cable Assembly Instructions

Y1157A Cable Kit Assembly	124
Y1158A Cable Kit Assembly	126
10-pin to 10-pin Cable	126
14-pin to 10-pin Cable	127
Y1159A Cable Kit Assembly	129

In addition to the cables provided in the Y1170A - Y1174A bracket kits, three cable kits are available for connecting switches and attenuators to the Y115xA distribution boards:

Y1157A

Y1158A

Y1159A

The cable kits used with each switch/attenuator and distribution board are identified in parentheses () in Table 1-2.



Y1157A Cable Kit Assembly

The Y1157A is a 10-pin ribbon connector to 9-pin D-Sub cable kit. The kit contains materials to build four cables and is used with the following distribution boards:

- Y1150A
- Y1152A
- Y1154A

The switches used with the Y1150A, Y1152A, and Y1154A which can also use the Y1157A cable are identified in Table 1-2.

The key to building the cables correctly is to understand the orientation of the socket pins on the distribution boards and the pin number orientation of the cable connectors. This orientation is shown in Figure A-1. When using the D-sub connector, always refer to the pin orientation shown in the figure. Do not use the pin numbers printed on the part.

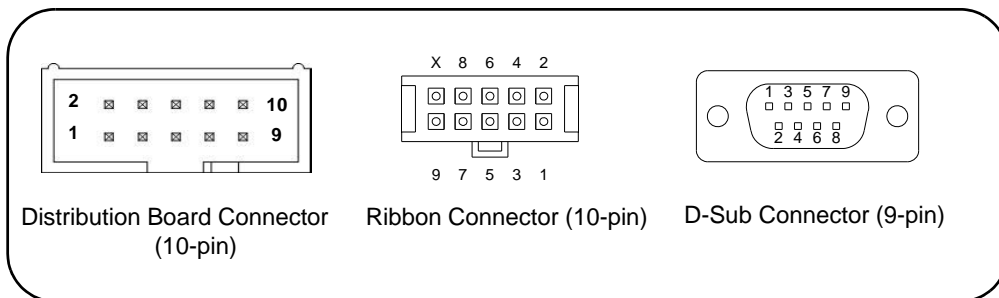

Figure A-1. Distribution Board Socket and Y1157A Cable Connector Orientation.

The steps for building the cables are as follows:

1. Cut the ribbon cable slightly longer than the desired length.
2. Position the D-Sub connector and the ribbon cable connector as shown in Figure A-2. Route the cable **through** the connectors, noting the location of cable pin 1. By convention, pin 1 is indicated in red (the dark line in the drawing).

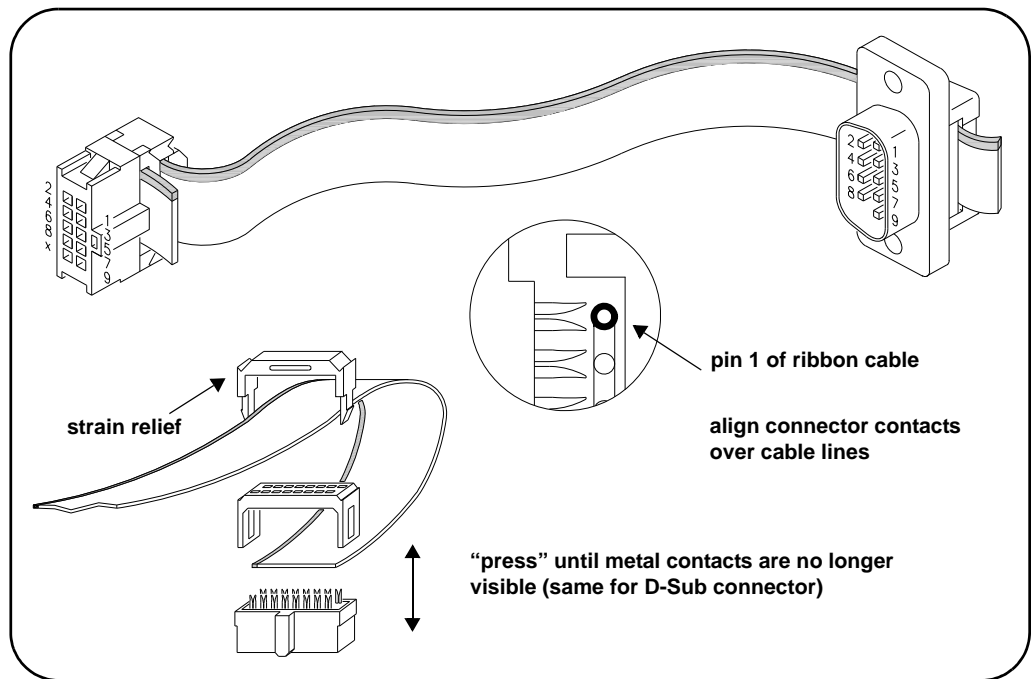

Figure A-2. Y1157A Connector Orientation and Ribbon Cable Routing.

3. Move the connectors to the ends of the cable, allowing for some overlap on the D-Sub connector end and strain relief on the ribbon cable connector end. **Note the orientation of the connectors and cable in the figure.**

4. Align the metal contacts of the ribbon connector over cable pin 1 (Figure A-2) and the other pins, press the ribbon cable connector onto the cable using a vise or clamp to press the contacts **evenly** through the cable insulation. Continue to press the connector until the metal contacts are no longer visible.

5. Fasten the strain relief clamp over the cable and into the ribbon cable connector as shown in Figure A-2. Remove any excess cable after the clamp is in place.

6. Align the metal contacts of the D-Sub connector over cable pin 1 and the other pins, press the D-Sub connector onto the cable using a vise or clamp to press the contacts **evenly** through the cable insulation. Continue to press the connector until the metal contacts are no longer visible. Remove any excess cable after the connector is in place.

Y1158A Cable Kit Assembly

The Y1158A is a 10-pin to 10-pin and 14-pin to 10-pin ribbon connector cable kit. The Y1158A kit contains materials to build two cables of either type or one of each and is used with the following distribution boards:

- Y1153A (10-pin to 10-pin cable)
- Y1154A (14-pin to 10-pin cable)

The switches used with the Y1153A and Y1154A which can also use the Y1158A cable are identified in Table 1-2.

The key to building the cables correctly is to understand the orientation of the socket pins on the distribution boards and the pin number orientation of the cable connectors. This orientation is shown in Figure A-3.

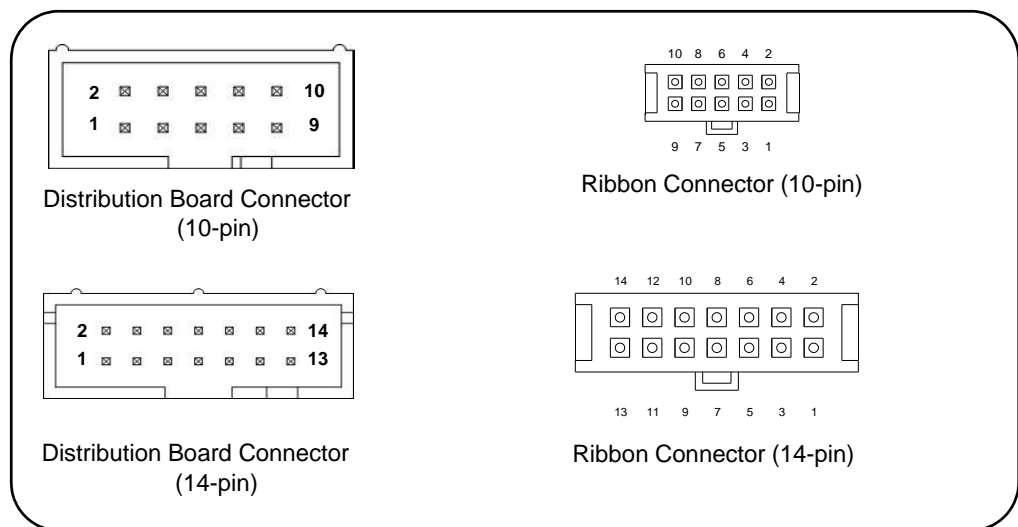

Figure A-3. Distribution Board Socket and Y1158A Cable Connector Orientation.

The steps for building the cables are as follows:

10-pin to 10-pin Cable

1. Cut the ribbon cable slightly longer than the desired length to allow for strain relief.

2. Position the ribbon cable connectors as shown in Figure A-4. Route the cable **through** the connectors, noting the location of pin 1 on the cable. By convention, pin 1 is indicated in red (the dark line in the drawing).

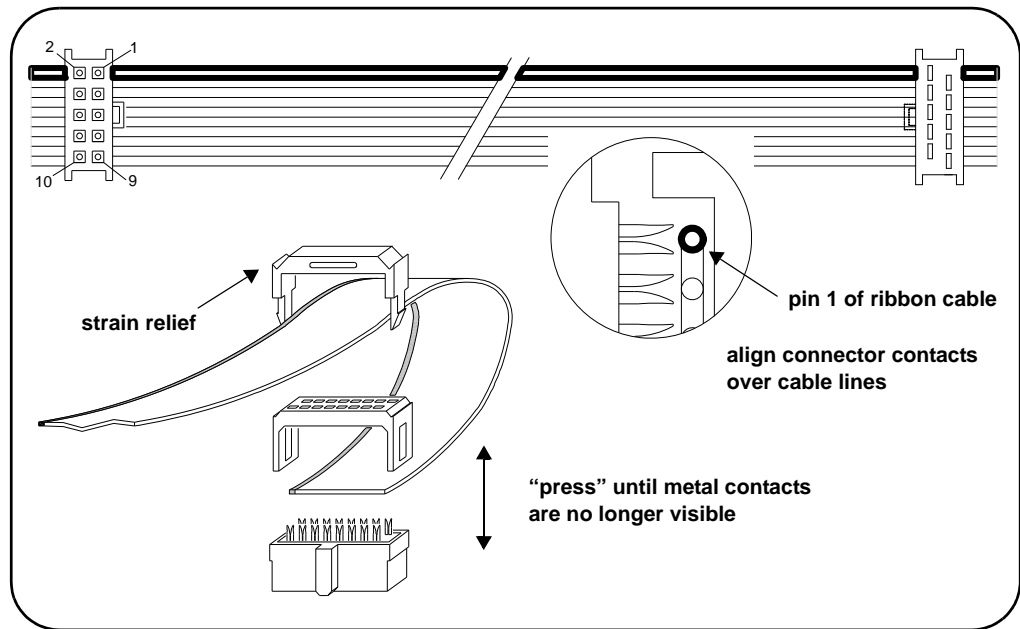

Figure A-4. Y1158A 10-pin to 10-pin Connector Orientation and Cable Routing.

3. Move the connectors towards the ends of the cable, with some overlap for strain relief. **Note the orientation of the connectors and cable in the figure.**

4. Align the metal contacts of the ribbon connector over cable pin 1 and the other pins, press the ribbon cable connector onto the cable using a vise or clamp to press the contacts **evenly** through the cable insulation. Continue to press the connector until the metal contacts are no longer visible.

5. Repeat Step 4 for the other connector.

6. Fasten the strain relief clamps over the cable and into the ribbon cable connectors as shown in Figure A-4. Remove any excess cable after the clamps are in place.

14-pin to 10-pin Cable

1. Cut the ribbon cable slightly longer than the desired length to allow for strain relief.

2. Position the ribbon cable connectors as shown in Figure A-5. Route the cable **through** the connectors, noting the location of pin 1 on the cable. By convention, pin 1 is indicated in red (the dark line in the drawing).

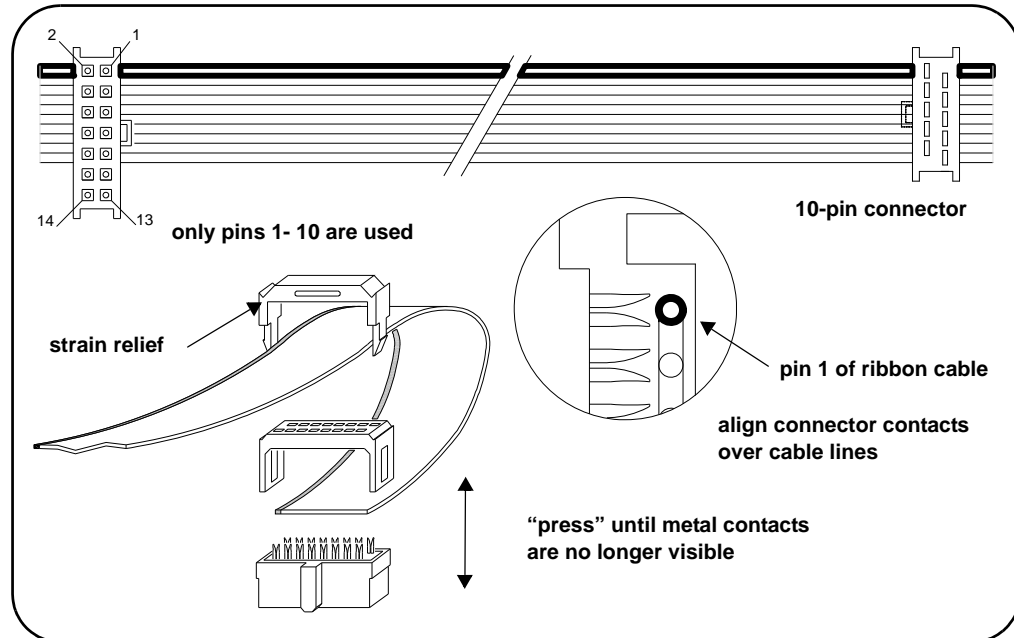

Figure A-5. Y1158A 14-pin to 10-pin Connector Orientation and Cable Routing.

3. Move the connectors towards the ends of the cable, with some overlap for strain relief. **Note the orientation of the connectors and cable in the figure.**

4. Align the metal contacts of the 14-pin ribbon connector over cable pins 1 through 10. The 14-pin connector will only make contact with pins 1 through 10. Press the ribbon cable connector onto the cable using a vise or clamp to press the contacts **evenly** through the cable insulation. Continue to press the connector until the metal contacts are no longer visible.

5. Repeat Step 4 for the 10-pin to 10-pin connector, noting the location of pin 1 on the cable.

6. Fasten the strain relief clamps over the cable and into the ribbon cable connectors as shown in Figure A-5. Remove any excess cable after the clamps are in place.

Y1159A Cable Kit Assembly

The Y1159A is a 16-pin to 16-pin ribbon connector cable kit. The Y1159A kit contains materials to build two cables and is used with the following distribution boards:

- Y1150A (LED position indicators)
- Y1151A (87104/87106/87406 and LED position indicators)
- Y1152A (87204/87206/87606 and LED position indicators)
- Y1153A (LED position indicators)
- Y1154A (LED position indicators)
- Y1155A (LED position indicators)

When connected to the LED1 or LED2 socket, the Y1159A cable allows you route the states of up to eight coils to LEDs mounted on a control panel. The Y1159A kit is also used with the Y1151A and Y1152A distribution boards for support of the switches listed above.

The key to building the cables correctly is to understand the orientation of the socket pins on the distribution boards and the pin number orientation of the cable connectors. This orientation is shown in Figure A-6.

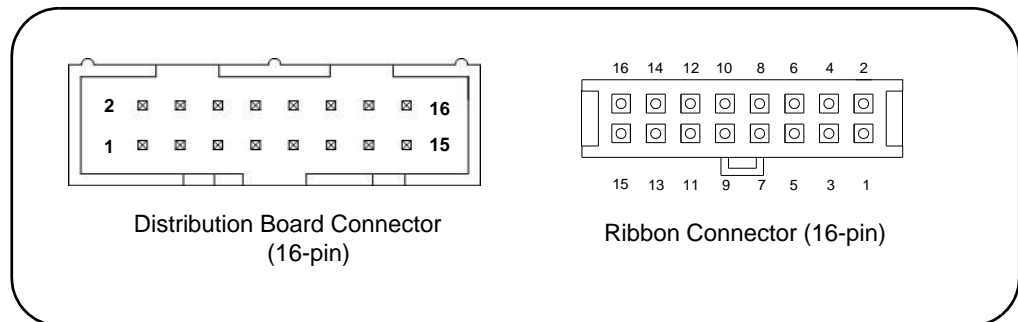

Figure A-6. Distribution Board Socket and Y1159A Cable Connector Orientation.

The steps for building the cables are as follows:

1. Cut the ribbon cable slightly longer than the desired length to allow for strain relief.

2. Position the ribbon cable connectors as shown in Figure A-7. Route the cable **through** the connectors, noting the location of pin 1 on the cable. By convention, pin 1 is indicated in red (the dark line in the drawing).

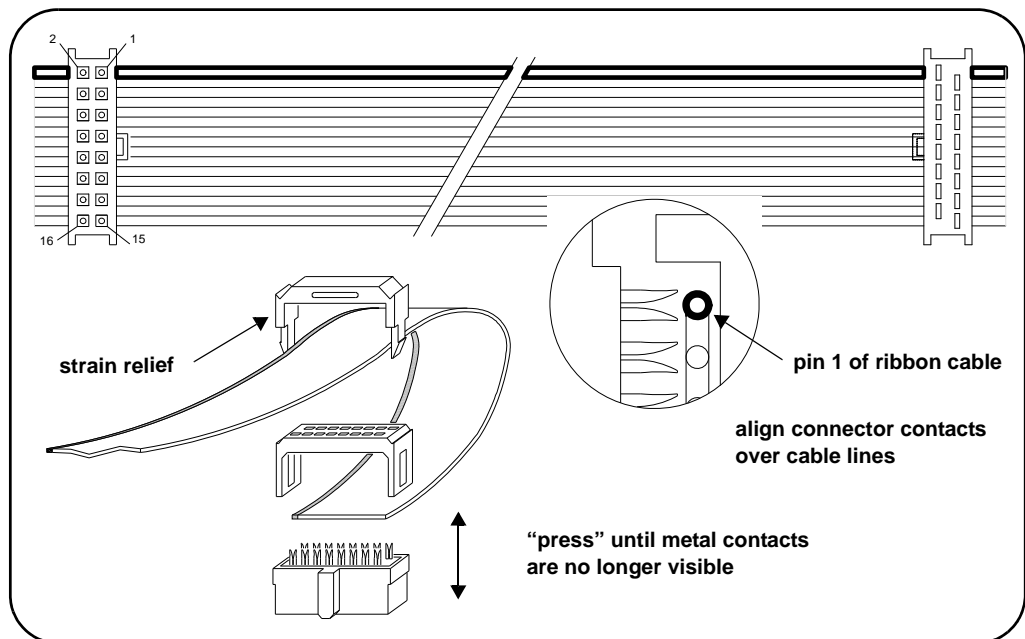

Figure A-7. Y1159A 16-pin to 16-pin Connector Orientation and Cable Routing.

3. Move the connectors towards the ends of the cable, with some overlap for strain relief. **Note the orientation of the connectors and cable in the figure.**

4. Align the metal contacts of the ribbon connector over cable pin 1 and the other pins, press the ribbon cable connector onto the cable using a vise or clamp to press the contacts **evenly** through the cable insulation. Continue to press the connector until the metal contacts are no longer visible.

5. Repeat Step 4 for the other connector.

6. Fasten the strain relief clamps over the cable and into the ribbon cable connectors as shown in Figure A-7. Remove any excess cable after the clamps are in place.

Numerics

- 34945EXT
 - bank numbering, 27
 - connection to L4490A, 25
 - connection to L4491A, 25
 - description, 3, 22
 - maximum number, 3, 22
- 34945EXT interconnections, 25
- 34945EXT module, 25
- 849x series
 - attenuator configuration and wiring, 37
- 849x series attenuators
 - changing settings, 86
 - presetting, 86
 - web programming, 86
- 849xx series
 - attenuator configuration and wiring, 36, 38
- 849xx series attenuators
 - changing settings, 86
 - presetting, 86
 - web programming, 86
- 87222 series
 - switch configuration and wiring, 39
- 87222 series switches
 - changing settings and enabling the channel drive, 88
 - presetting the bank, 88
 - web interface programming, 88
- 8765 series
 - switch configuration and wiring, 41
- 876x series
 - switch configuration and wiring, 40
- 876x series switches
 - changing settings and enabling the channel drive, 90
 - presetting the bank, 90
 - web interface programming, 90
- 876xK series
 - switch configuration and wiring, 42
- 876xM series
 - switch configuration and wiring, 35
- 876xM series switches
 - changing settings, 86
 - presetting, 86
 - web programming, 86
- 87xxx series
 - switch configuration and wiring, 33, 34
- 87xxx series switches
 - changing settings and enabling the channel drive, 82, 84
 - presetting the bank, 82, 84
 - web interface programming, 82, 84

A

- accessories for the RF platform, 4

- adding instruments to the interface, 49
- address string
 - GPIB, 55
- addressing
 - IP addresses and host names, 53
- Agilent Connection Expert
 - GPIB configuration, 53
 - Interactive IO, 56
 - locating instruments, 50
- Agilent IO libraries
 - computer requirements, 47
 - installation, 47
- applying power, 57
- attenuator configuration and wiring
 - 849x series, 37
 - 849xx series, 36, 38
- attenuator configurations, 31

B

- bank commands, 27
- bank configuration window, 71
- bank diagram, 72
- bank preset
 - 87222 series, 88
 - 876x series, 90
 - 87xxx series, 82, 84
 - L7222 series, 88
 - L7xxx series, 82
 - N1810 series, 80
 - U9397A/C, 90
- brackets, 7
 - Y1170A and Y1171A kits, 8
 - Y1172A kit, 9
 - Y1173A kit, 10
 - Y1174A kit, 11
 - Y1175A kit, 12
- browser web control page, 67
 - bank configuration window, 71
 - bank diagram, 72
 - IsOpen/IsClosed, 72
 - legend, 72
 - observe only / allow full control, 69
 - position indicator, 72
 - remote module configuration window, 69
 - SCPI command interface, 72
 - switch/attenuator channel configuration window, 70
 - viewing remote modules, 69
 - web interface programming, 80

C

- cable kits
 - Y1157A, 124
 - Y1158A, 126
 - Y1159A, 129
- changing the GPIB address, 55
- channel numbering, 27

- channel pairing, 28
- channel/relay relationship, 28
- channels
 - non-paired, 28
- command execution times, 118
- command summary
 - SCPI, 100
- commands
 - bank, 27
 - module, 27
- computer configuration, 53
- configuration
 - LAN, 49
- connecting switches to brackets, 7
- Connection Expert
 - GPIB configuration, 53
 - Interactive IO, 56
 - locating instruments, 50
- Connection Expert utility
 - LAN configuration, 49
- controller box
 - DC outputs, 24

D

- DC output power supplies, 24
- defining sequences, 92
- development environments, 46
 - logging commands for transfer to, 73
- diagnostics, 75
- digital data
 - 34959A, 121
- digital IO and relay drive option, 93
 - configuration, 96
 - connector pin definitions, 93
- digital IO and relay driver option, 121
- digital IO functions, 121
- digital IO read and write timing diagrams, 122
- downloading firmware updates, 58
- downloading the IVI-COM driver, 63
- driver updates, 58
- drivers, 46
- drivers, required, 46, 86, 97
- dual-coil switches and attenuators, 112

E

- environments
 - operating and storage, 3
- external power supplies, 25
- external power supply considerations, 30

F

- factory settings, 96, 97

- firmware updates, 58
 - downloads, 58
 - installation, 59
 - installation with L4491A option 002, 61
 - update utility, 58
- front panel LED descriptions, 57

G

- GPIB
 - adding instruments to the configuration, 54
 - address string, 55
 - changing the address, 55
 - using Agilent Connection Expert, 53
- GPIB address
 - changing, 55
- GPIB configuration, 53
- GPIB interface
 - general information, 31

H

- host name and IP address
 - obtaining, 67
- host names and IP addresses, 52

I

- input power, 3
- installation
 - Agilent IO libraries, 47
 - IVI drivers, 48
 - trays, 13
- installing switches and attenuators, 6
- instrument addressing
 - GPIB address string, 55
 - IP addresses and host names, 53
- instrument configuration, 23
- instrument interconnections, 23
 - 34945EXT to 34945EXT, 25
 - 34945EXT to external power supplies, 25
 - L4490A/L4491A to 34945EXT, 25
 - PC to L4490A/L4491A, 25
- instruments
 - locating, 50
- Interactive IO, 56
- interface configuration
 - GPIB, 49
 - LAN, 49
- internal supply considerations, 29
- IO libraries
 - computer requirements, 47
 - installation, 47
- IP address and host name
 - obtaining, 67
- IP addresses and host names, 52

- isolated LAN networks, 22
- IsOpen/IsClosed, 72
- IVI drivers
 - installation, 48
- IVI-COM
 - driver updates, 58, 63

K

- kits
 - Y1170A, 8
 - Y1171A, 8
 - Y1172A, 9
 - Y1173A, 10
 - Y1174A, 11
 - Y1175A, 12

L

- L4411A, programming environments, 46, 86, 97
- L4445A
 - description, 3, 22
 - recovery time, 115
 - settling time, 115
- L4490A
 - bank configuration window, 71
 - browser web control page, 67
 - channel pairing, 112
 - connection to 34945EXT, 25
 - continuous drive mode, 110
 - drive modes, 109
 - dual drive mode, 112
 - factory settings, 96, 97
 - firmware updates, 58
 - open-collector drive mode, 109
 - option 004, 93
 - pulse drive mode, 115
 - remote module configuration window, 69
 - SCPI command interface, 72
 - SCPI command summary, 100
 - single drive mode, 110
 - switch tray, 13
 - switch/attenuator channel configuration window, 70
 - TTL drive mode, 109
 - using the web-enabled interface, 66
 - web interface home page, 67
 - web interface programming, 80
- L4490A/L4491A
 - controller box DC outputs, 24

- L4491A
 - bank configuration window, 71
 - browser web control page, 67
 - channel pairing, 112
 - connection to 34945EXT, 25
 - continuous drive mode, 110
 - drive modes, 109
 - dual drive mode, 112
 - factory settings, 96, 97
 - firmware updates, 58
 - multiport front panel, 18
 - open-collector drive mode, 109
 - option 004, 93
 - pulse drive mode, 115
 - remote module configuration window, 69
 - SCPI command interface, 72
 - SCPI command summary, 100
 - single drive mode, 110
 - switch bays, 14
 - switch tray, 16
 - switch/attenuator channel configuration window, 70
 - TTL drive mode, 109
 - using the web-enabled interface, 66
 - web interface home page, 67
 - web interface programming, 80
- L4491A option 002
 - firmware updates, 61
- L7222 series
 - switch configuration and wiring, 39
- L7222 series switches
 - changing settings and enabling the channel drive, 88
 - presetting the bank, 88
 - web interface programming, 88
- L7xxx series
 - switch configuration and wiring, 33
- L7xxx series switches
 - changing settings and enabling the channel drive, 82
 - presetting the bank, 82
 - web interface programming, 82
- LAN
 - default configuration settings, 58
 - network configuration, 22
 - selecting a configuration, 22
- LAN configuration, 49
- LAN network
 - considerations, 22
 - selecting, 22
- LED descriptions, 57
- LED drive indicators, 120
- legend, 72
- locating information, 2
- locating instruments, 50
- logging commands, 73

M

- master module, 3, 22

- materials included with shipment, 3
- module commands, 27
- multiport front panel, 18

N

- N1810 series
 - switch configuration and wiring, 32
- N1810 series switches
 - changing settings and enabling the channel drive, 80
 - presetting the bank, 80
 - web interface programming, 80
- N1811 series
 - switch configuration and wiring, 32
- N1812 series
 - switch configuration and wiring, 32
- network configuration, 22
 - private LAN considerations, 22
 - site LAN considerations, 23
- network considerations, 22
- non-paired channels, 28
- numbering
 - channels, 27

O

- operating environment, 3
- option 004, 121
- options
 - 001, 18
 - 004, 93
 - 005, 14
 - 006, 16
- output power supplies, 24
- overcurrent conditions, 117
 - external supplies, 118

P

- pairing
 - channels, 28
- pairing channels, 113
- PC connection to instrument, 25
- position indicator, 72
- position indicator verification, 78
- power requirements, 3
- power supplies
 - external, 25
 - external considerations, 30
 - internal considerations, 29
- power supply considerations, 28
- power-on and reset states, 96
- private LAN networks, 22
- product options, 13
- programming sequences, 92
- proxy server, 53
- pulsed actuation mode, 115

R

- recommended accessories
 - table, 4
- recommended drivers, 46
- recommended use model, 2
- recovery time
 - L4445A, 115
- reference information, 119
 - command execution times, 118
 - digital IO and relay driver option 004, 121
 - digital IO read and write timing diagrams, 122
 - drive modes, 109
 - dual-coil devices, 112
 - LED drive indicators, 120
 - overcurrent conditions, 117
 - pairing channels, 113
 - pulsed actuation mode, 115
 - single coil devices, 110
- relay drive and digital IO option, 93
 - configuration, 96
 - connector pin definitions, 93
- relay/channel relationship, 28
- remote module configuration window, 69
- remote modules
 - viewing, 69
- removing the top and bottom covers, 6
- required drivers, 46, 86, 97
- reset and power-on states, 96
- RF platform
 - position indicator verification, 78
 - verification, 75
 - verification sequence, 75
- RF platform accessories, 4
- RF platform
 - installing switches and attenuators, 6

S

- SCPI command interface, 72
 - logging commands, 73
- SCPI command summary, 100
- sequence programming, 92
 - defining a sequence, 92
- settling time
 - L4445A, 115
- shipment
 - materials included, 3
- side panels
 - removing, 6
- single-coil switches and attenuators, 110
- site LAN considerations, 23
- slave module, 3, 22
- software installation
 - Agilent IO libraries, 47
 - computer requirements, 47
 - IVI drivers, 48
- software requirements, 46

- storage environment, 3
- switch bays
 - L4491A, 14
- switch brackets, 7
- switch configuration and wiring
 - 87222 series, 39
 - 8765 series, 41
 - 876x series, 40
 - 876xK series, 42
 - 876xM series, 35
 - 87xxx series, 33, 34
 - L7222 series, 39
 - L7xxx series, 33
 - N1810 series, 32
 - U9397A/C, 43
- switch configurations, 31
- switch control tables, 104
 - Y1150A, 104
 - Y1151A, 104
 - Y1152A, 105
 - Y1153A, 106
 - Y1154A, 106
 - Y1155A, 107
- switch installation
 - bracket-switch assembly, 7
 - switch position indicators, 119
 - switch state verification, 119
 - switch states and position indicators, 119
- switch trays, 13
 - L4490A, 13
 - L4491A, 16
- switch/attenuator channel configuration window, 70

T

- technical support
 - phone numbers, ii
 - Web site, ii
- top and bottom covers
 - removing, 6
- troubleshooting, 75

U

- U9397A/C
 - switch configuration and wiring, 43
- U9397A/C switches
 - changing settings and enabling the, 90
 - presetting the bank, 90
 - web interface programming, 90
- updating firmware, 58
- USB interface
 - general information, 31
- use model, 2
- using the GPIB and USB interface
 - general information, 31

V

verification

L4445A, [119](#)

RF platform, [75](#)

verification sequence, [75](#)

viewing remote modules, [69](#)

W

web interface programming, [80](#)

8490x series attenuators, [86](#)

849x series attenuators, [86](#)

87222 series switches, [88](#)

876x series switches, [90](#)

876xM series switches, [86](#)

87xxx series switches, [82](#), [84](#)

L7222 series switches, [88](#)

L7xxx series switches, [82](#)

N1810 series switches, [80](#)

U9397A/C switches, [90](#)

Web-enabled instrument interface and

Interactive IO, [55](#)

Web-enabled interface

browser web control page, [67](#)

connecting to the instrument, [67](#)

getting started, [66](#)

Y

Y1150A

configuration and wiring, [32](#)

switch control table, [104](#)

Y1151A

configuration and wiring, [33](#)

switch control table, [104](#)

Y1152A

configuration and wiring, [34](#)

switch control table, [105](#)

Y1153A

configuration and wiring, [35](#)

switch control table, [106](#)

Y1153A configuration and wiring, [36](#),

[37](#), [38](#)

Y1154A

configuration and wiring, [39](#)

switch control table, [106](#)

Y1155A

LED connector pin definitions, [107](#)

LED connector pins, [108](#)

switch control table, [107](#)

Y1155A configuration and wiring, [40](#),

[41](#), [42](#), [43](#)

Y1156A

position indicator verification, [78](#)

verification board, [75](#)

verification sequence, [75](#)

Y1157A cable, [32](#)

Y1157A cable kit assembly, [124](#)

Y1158A cable, [35](#), [36](#), [38](#), [39](#)

Y1158A cable kit assembly, [126](#)

Y1159A cable, [33](#), [34](#)

Y1159A cable kit assembly, [129](#)

Y1170A

cable, [32](#)

Y1171A

cable, [32](#)

Y1172A

cable, [33](#), [34](#)

Y1173A

cable, [39](#)

Y1174A

cable, [36](#)